

Approval body for construction products  
and types of construction

Bautechnisches Prüfamt

An institution established by the Federal and  
Laender Governments



## European Technical Assessment

**ETA-20/0729**  
**of 26 November 2020**

English translation prepared by DIBt - Original version in German language

### General Part

Technical Assessment Body issuing the  
European Technical Assessment:

Deutsches Institut für Bautechnik

Trade name of the construction product

fischer injection system FIS V Plus for masonry

Product family  
to which the construction product belongs

Metal Injection anchors for use in masonry

Manufacturer

fischerwerke GmbH & Co. KG  
Otto-Hahn-Straße 15  
79211 Denzlingen  
DEUTSCHLAND

Manufacturing plant

fischerwerke

This European Technical Assessment  
contains

139 pages including 3 annexes which form an integral  
part of this assessment

This European Technical Assessment is  
issued in accordance with Regulation (EU)  
No 305/2011, on the basis of

EAD 330076-00-0604, Edition 11/2017

The European Technical Assessment is issued by the Technical Assessment Body in its official language. Translations of this European Technical Assessment in other languages shall fully correspond to the original issued document and shall be identified as such.

Communication of this European Technical Assessment, including transmission by electronic means, shall be in full. However, partial reproduction may only be made with the written consent of the issuing Technical Assessment Body. Any partial reproduction shall be identified as such.

This European Technical Assessment may be withdrawn by the issuing Technical Assessment Body, in particular pursuant to information by the Commission in accordance with Article 25(3) of Regulation (EU) No 305/2011.

**Specific Part**

**1 Technical description of the product**

The fischer injection system FIS V Plus for masonry is a bonded anchor (injection type) consisting of a mortar cartridge with injection mortar fischer FIS V Plus, FIS VS Plus Low Speed and FIS VW Plus High Speed, a perforated sieve sleeve and an anchor rod with hexagon nut and washer or an internal threaded rod in the range of M6 to M16. The steel elements are made of zinc coated steel, stainless steel or high corrosion resistant steel.

The anchor rod is placed into a drilled hole filled with injection mortar and is anchored via the bond between steel element, injection mortar and masonry and mechanical interlock.

The product description is given in Annex A.

**2 Specification of the intended use in accordance with the applicable European Assessment Document**

The performances given in Section 3 are only valid if the anchor is used in compliance with the specifications and conditions given in Annex B.

The verifications and assessment methods on which this European Technical Assessment is based lead to the assumption of a working life of the anchor of at least 50 years. The indications given on the working life cannot be interpreted as a guarantee given by the producer, but are to be regarded only as a means for choosing the right products in relation to the expected economically reasonable working life of the works.

**3 Performance of the product and references to the methods used for its assessment**

**3.1 Mechanical resistance and stability (BWR 1)**

Essential characteristic	Performance
Characteristic values for resistance	See Annexes B20, C 1 to C 110
Displacements	See Annex C 110
Durability	See annex B 2

**3.2 Safety in case of fire (BWR 2)**

Essential characteristic	Performance
Reaction to fire	Class A1

**3.3 Hygiene, health and the environment (BWR 3)**

Essential characteristic	Performance
Content, emission and/or release of dangerous substances	No performance assessed

**4 Assessment and verification of constancy of performance (AVCP) system applied, with reference to its legal base**

In accordance with the European Assessment Document EAD 330076-00-0604 the applicable European legal act is: [97/177/EC].

The system to be applied is: 1

**5 Technical details necessary for the implementation of the AVCP system, as provided for in the applicable European Assessment Document**

Technical details necessary for the implementation of the AVCP system are laid down in the control plan deposited at Deutsches Institut für Bautechnik.

Issued in Berlin on 26 November 2020 by Deutsches Institut für Bautechnik

Dipl.-Ing. Beatrix Wittstock  
Head of Section

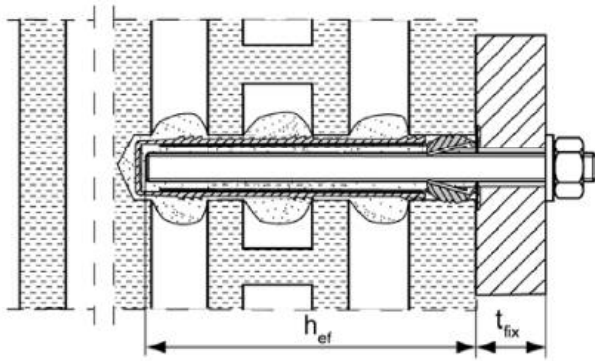
*beglaubigt:*  
Baderschneider



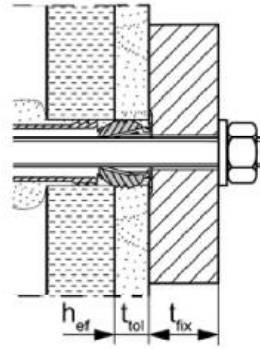
**Installation conditions part 1**

**Anchor rods with perforated sleeve FIS H K; Installation in perforated and solid brick masonry**

**Pre-positioned anchorage:**

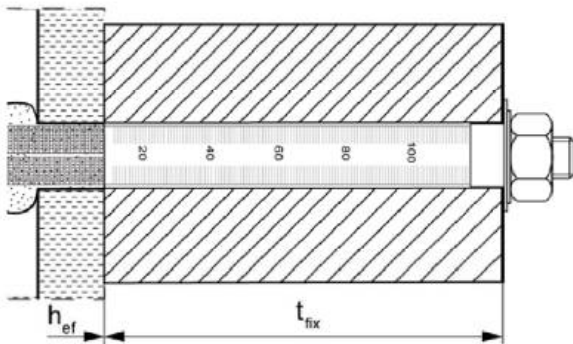


**Installation with render bridge**

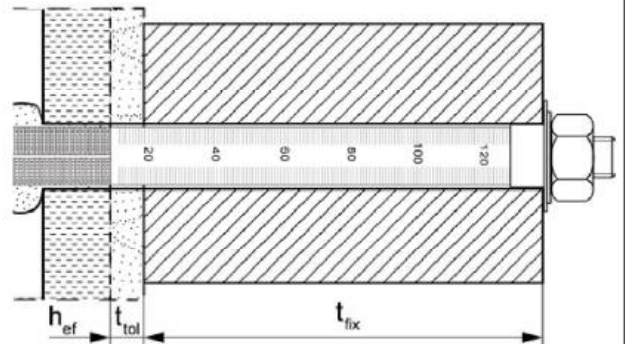


**Size of the perforated sleeve:** FIS H 12x50 K FIS H 16x85 K FIS H 20x85 K FIS H 20x200 K  
FIS H 12x85 K FIS H 16x130 K FIS H 20x130 K

**Push through anchorage:**



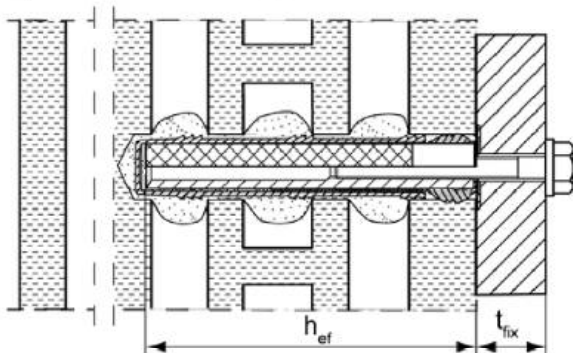
**Installation with render bridge**



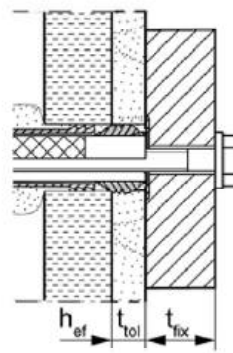
**Size of the perforated sleeve:** FIS H 18x130/200 K FIS H 22x130/200 K

**Internal threaded anchor FIS E with perforated sleeve FIS H K; Installation in perforated and solid brick masonry**

**Pre-positioned anchorage:**



**Installation with render bridge**



Pictures not to scale

$h_{ef}$  = effective anchorage depth

$t_{tol}$  = thickness of unbearing layer (e.g. plaster)

$t_{fix}$  = thickness of fixture

fischer injection system FIS V Plus for masonry

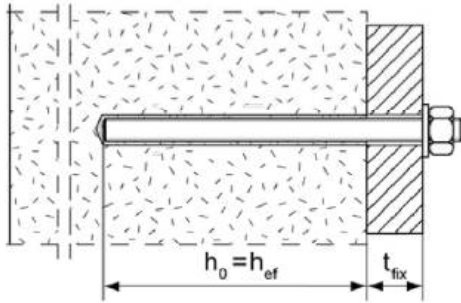
**Product description**  
Installation conditions part 1,  
Anchor rods and internal threaded anchor with perforated sleeve

**Annex A 1**

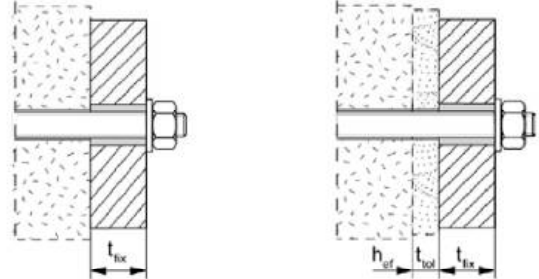
## Installation conditions part 2

**Anchor rods without perforated sleeve FIS H K;  
installation in solid brick masonry and autoclaved aerated concrete**

**Pre-positioned anchorage:**



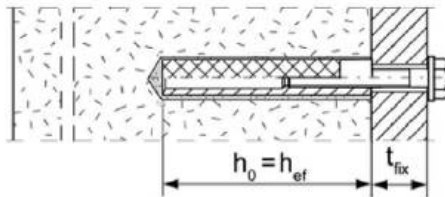
**Push through anchorage: Annular gap filled with mortar**



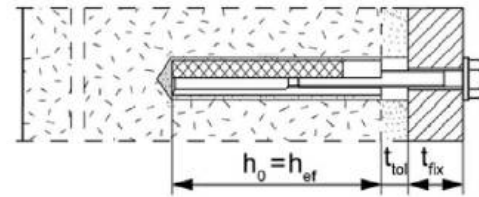
Installation with  
render bridge

**Internal threaded anchors FIS E without perforated sleeve FIS H K;  
installation in solid brick masonry and autoclaved aerated concrete**

**Pre-positioned anchorage:**



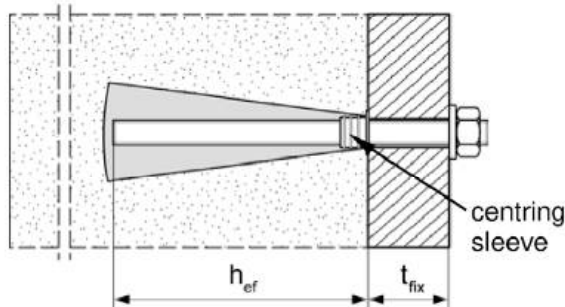
Installation with render bridge



**Anchor rods and internal threaded anchors FIS E without perforated sleeve FIS H K; installation with  
centring sleeve in autoclaved aerated concrete with conical drill hole  
(installation with special conic drill bit PBB)**

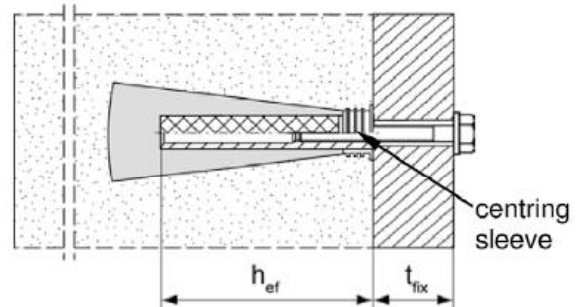
**Pre-positioned anchorage:**

anchor rods M8, M10, M12



**Pre-positioned anchorage:**

Internal threaded anchor FIS E 11x85 M6 / M8



Pictures not to scale

$h_0$  = depth of drill hole

$h_{ef}$  = effective anchorage depth

$t_{tol}$  = thickness of unbearing layer (e.g. plaster)

$t_{fix}$  = thickness of fixture

fischer injection system FIS V Plus for masonry

**Product description**

Installation conditions part 2, Anchor rods and internal threaded anchor without perforated sleeve / with centring sleeve

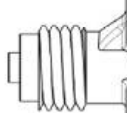
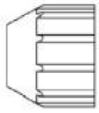
**Annex A 2**

**Overview system components part 1**

**Mortar cartridge (shuttle cartridge) with sealing cap**

①

Size: 350 ml, 360 ml, 390 ml, 550 ml, 825 ml



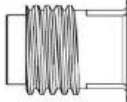
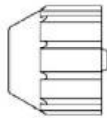
**Imprint:** fischer FIS V Plus or FIS VS Plus Low Speed or FIS VW Plus High Speed, processing notes, shelf-life, hazard code, piston travel scale (optional), curing time and processing time (depending on temperature), size, volume



**Mortar cartridge (coaxial cartridge) with sealing cap**

①

Size: 100 ml, 150 ml, 300 ml, 380 ml, 400 ml, 410 ml



**Imprint:** fischer FIS V Plus or FIS VS Plus Low Speed or FIS VW Plus High Speed, processing notes, shelf-life, hazard code, piston travel scale (optional), curing time and processing time (depending on temperature), size, volume

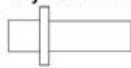


**Static mixer MR Plus with injection adapter and center sleeve for aerated concrete**

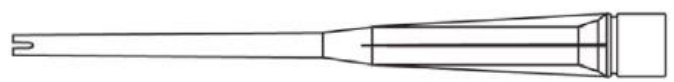
centring sleeve



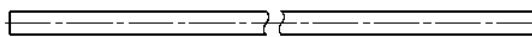
Injection adapter



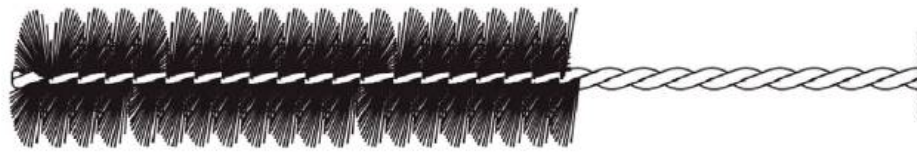
Static mixer



Extension tube



**Cleaning brush BS**



**Blow-out pump ABG or ABP**



Pictures not to scale



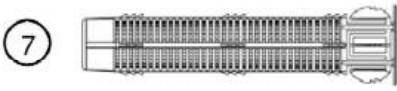




fischer injection system FIS V Plus for masonry

**Product description**



Overview system components part 1: cartridge / static mixer / cleaning tools

**Annex A 3**



<b>Overview system components part 2</b>	
<b>fischer anchor rod</b>	
	Size: M6, M8, M10, M12, M16
<b>Internal threaded anchor FIS E</b>	
	Size: 11x85 M6 / M8 15x85 M10 / M12
<b>Perforated sleeve FIS H K</b>	
	Size: FIS H 12x50 K FIS H 12x85 K FIS H 16x85 K FIS H 20x85 K
	Size: FIS H 16x130 K FIS H 20x130 K FIS H 20x200 K
<b>Perforated sleeve FIS H K (push through anchorage)</b>	
	Size: FIS H 18x130/200 K FIS H 22x130/200 K
<b>Washer</b>	
	
<b>Hexagon nut</b>	
	
Pictures not to scale	
<b>fischer injection system FIS V Plus for masonry</b>	<b>Annex A 4</b>
<b>Product description</b> Overview system components part 2: steel parts / perforated sleeve	

<b>Table A5.1: Materials</b>				
<b>Part</b>	<b>Designation</b>	<b>Material</b>		
1	Mortar cartridge	Mortar, hardener; filler		
		Steel	Stainless steel R	High corrosion-resistant steel HCR
		zinc plated	acc. to EN 10088-1:2014 Corrosion resistance class CRC III acc. to EN 1993-1-4:2015	acc. to EN 10088-1:2014 Corrosion resistance class CRC V acc. to EN 1993-1-4:2015
2	Anchor rod	Property class 4.6; 4.8; 5.8 oder 8.8; EN ISO 898-1: 2013 zinc plated $\geq 5\mu\text{m}$ , ISO 4042:2018 Zn5/An(A2K) or hot-dip galvanised EN ISO 10684:2004 $f_{uk} \leq 1000 \text{ N/mm}^2$ $A_5 > 8\%$ fracture elongation	Property class 50, 70 or 80 EN ISO 3506-1:2009 1.4401; 1.4404; 1.4578; 1.4571; 1.4439; 1.4362; 1.4062; 1.4662; 1.4462; EN 10088-1:2014 $f_{uk} \leq 1000 \text{ N/mm}^2$ $A_5 > 8\%$ fracture elongation	Property class 50 or 80 EN ISO 3506-1:2009 or property class 70 with $f_{yk} = 560 \text{ N/mm}^2$ 1.4565; 1.4529 EN 10088-1:2014 $f_{uk} \leq 1000 \text{ N/mm}^2$ $A_5 > 8\%$ fracture elongation
3	Washer ISO 7089:2000	zinc plated $\geq 5\mu\text{m}$ , ISO 4042:2018 Zn5/An(A2K) or hot-dip galvanised EN ISO 10684:2004	1.4401; 1.4404; 1.4578; 1.4571; 1.4439; 1.4362; EN 10088-1:2014	1.4565; 1.4529 EN 10088-1:2014
4	Hexagon nut	Property class 5 or 8; EN ISO 898-2:2012 zinc plated $\geq 5\mu\text{m}$ , ISO 4042:2018 Zn5/An(A2K) or hot-dip galvanised ISO 10684:2004	Property class 50, 70 or 80 EN ISO 3506-1:2009 1.4401; 1.4404; 1.4578; 1.4571; 1.4439; 1.4362; EN 10088-1:2014	Property class 50, 70 or 80 EN ISO 3506-1:2009 1.4565; 1.4529 EN 10088-1:2014
5	Internal threaded anchor FIS E	Property class 5.8; EN 10277-1:2008-06 zinc plated $\geq 5\mu\text{m}$ , ISO 4042:2018 Zn5/An(A2K)	Property class 70 EN ISO 3506-1:2009 1.4401; 1.4404; 1.4578; 1.4571; 1.4439; 1.4362; EN 10088-1:2014	Property class 70 EN ISO 3506-1:2009 1.4565; 1.4529 EN 10088-1:2014
6	Commercial standard screw or threaded rod for internal threaded anchor FIS E	Property class 5.8 or 8.8; EN ISO 898-1:2013 zinc plated $\geq 5\mu\text{m}$ , ISO 4042:2018 Zn5/An(A2K)	Property class 70 EN ISO 3506-1:2009 1.4401; 1.4404; 1.4578; 1.4571; 1.4439; 1.4362; EN 10088-1:2014	Property class 70 EN ISO 3506-1:2009 1.4565; 1.4529 EN 10088-1:2014
7	Perforated sleeve and centring sleeve	PP / PE		
fischer injection system FIS V Plus for masonry				<b>Annex A 5</b>
<b>Product description</b> Materials				

<b>Specifications of intended use (part 1)</b>			
<b>Table B1.1: Overview use and performance categories</b>			
Anchorages subject to		<b>fischer injection system FIS V Plus for masonry</b>	
Hole drilling with hammer drill mode 		all bricks; without C28 to C48, C75 to C78	
Hole drilling with rotary drill mode 		all bricks	
Static and quasi static load, in masonry		all bricks	
Use category	dry or wet masonry	all bricks	
Installation	Pre-positioned anchorage	Anchor rod or internal threaded anchor (in solid brick masonry and autoclaved aerated concrete)	Perforated sleeve with anchor rod or internal threaded anchor (in perforated and solid brick masonry)  Size: FIS H 12x50 K FIS H 12x85 K FIS H 16x85 K FIS H 16x130 K FIS H 20x85 K FIS H 20x130 K FIS H 20x200 K
	Push through anchorage	Anchor rod; use only in cylindrical drill hole (in solid brick masonry and autoclaved aerated concrete)	Perforated sleeve with anchor rod (in perforated and solid brick masonry)  Size: FIS H 18x130/200 K FIS H 22x130/200 K
Installation conditions	category d/d category w/d category w/w	all bricks	
Installation direction		D3 (downward and horizontal and upwards (e.g. overhead) installation)	
Installation temperature		$T_{i,min} = 0\text{ °C}$ bis $T_{i,max} = +40\text{ °C}$	
In-service temperature	Temperature range Tb	-40 °C to +80 °C	(max. short term temperature +80 °C max. long term temperature +50 °C)
	Temperature range Tc	-40 °C to +120 °C	(max. short term temperature +120 °C; max. long term temperature +72 °C)
fischer injection system FIS V Plus for masonry		<b>Annex B 1</b>	
<b>Intended Use</b> Specifications (part 1)			

## Specifications of intended use (part 2)

### Anchorage subject to:

- Static and quasi-static loads

### Base materials:

- Solid brick masonry (Use category b) and autoclaved aerated concrete (Use category d), acc. to Annex B 13 / B 14
- Hollow brick masonry (use category c), according to Annex B 13 / B 14
- For minimum thickness of masonry member is  $h_{ef}+30\text{mm}$
- Mortar strength class of the masonry M2,5 at minimum according to EN 998-2:2010
- For other bricks in solid masonry, hollow or perforated masonry and autoclaved aerated concrete, the characteristic resistance of the anchor may be determined by job site tests according to EOTA Technical Report TR 053, Annex B under consideration of the  $\beta$ -factor according to Annex C 110, Table C110.1

Note (only applies to solid bricks and autoclaved aerated concrete):

The characteristic resistance is also valid for larger brick sizes, higher compressive strength and higher raw density of the masonry unit.

### Temperature Range:

- **Tb:** From -40°C to +80°C (max. short term temperature +80°C and max. long term temperature +50°C)
- **Tc:** From -40°C to +120°C (max. short term temperature +120°C and max. long term temperature +72°C)

### Use conditions (Environmental conditions):

- **X1:** Structures subject to dry internal conditions exist  
(zinc coated steel, stainless steel or high corrosion resistant steel)
- **X2:** Structures subject to external atmospheric exposure including industrial and marine environment or exposure to permanently damp internal condition, if no particularly aggressive conditions exist  
(stainless steel or high corrosion resistant steel)
- **X3:** Structures subject to external atmospheric exposure and to permanently damp internal condition, if other particularly aggressive conditions exist (high corrosion resistant steel)

Note: Particular aggressive conditions are e.g. permanent, alternating immersion in seawater or the splash zone of seawater, chloride atmosphere of indoor swimming pools or atmosphere with extreme chemical pollution (e.g. in desulphurization plants or road tunnels where de-icing materials are used)

fischer injection system FIS V Plus for masonry

**Intended Use**  
Specifications (part2)

**Annex B 2**

## Specifications of intended use (part 2 continued)

### Design:

- The anchorages have to be designed in accordance with EOTA Technical Report TR 054, Design method A under the responsibility of an engineer experienced in anchorages and masonry work.

Applies to all bricks, if no other values are specified:

$$N_{Rk} = N_{Rk,b} = N_{Rk,p}$$

$$V_{Rk} = V_{Rk,b} = V_{Rk,c}$$

For the Calculation of pulling out a brick under tension load  $N_{Rk,pb}$  or pushing out a brick under shear load  $V_{Rk,pb}$  see EOTA Technical Report TR 054.

$N_{Rk,s}$ ,  $V_{Rk,s}$  and  $M^0_{Rk,s}$  see annex C1-C3

Factors for job site tests and displacements see Annex C110

- Verifiable calculation notes and drawings have to be prepared taking account the relevant masonry in the region of the anchorage, the loads to be transmitted and their transmission to the supports of the structure. The position of the anchor is indicated on the design drawings.

### Installation:

- Category d/d: - Installation and use in dry structures
- Category w/w: - Installation and use in dry and wet structures
- Category w/d: - Installation in wet structures and use in dry structures
- Hole drilling see Annex C (drilling method)
- In case of aborted hole: The hole shall be filled with mortar
- Bridging of unbearing layer (e.g. plaster) at perforated brick masonry see Annex B 6, Table B6.1
- Anchor installation carried out by appropriately qualified personnel and under the supervision of the person responsible for technical matters of the site
- Fastening screws or anchor rods (including nut and washer) must comply with the appropriate material and property class of the fischer internal threaded anchor FIS E.

- minimum curing time see Annex B 8, Table B8.2

- Commercial standard threaded rods, washers and hexagon nuts may also be used if the following requirements are fulfilled:

Material dimensions and mechanical properties of the metal parts according to the specifications are given in Annex A 5, Table 5.1

Conformation of material and mechanical properties of the metal parts by inspection certificate 3.1 according to EN 10204:2004, the documents shall be stored

Marking of the anchor rod with the envisage embedment depth. This may be done by the manufacturer of the rod or by a person on job site

fischer injection system FIS V Plus for masonry

**Intended Use**  
Specifications (part2 continued)

**Annex B 3**



**Table B4.1:** Installation parameters for anchor rods in solid bricks and autoclaved aerated concrete without perforated sleeves

Anchor rod	Thread	M6	M8	M10	M12	M16
Nominal drill hole diameter	$d_0$ [mm]	8	10	12	14	18
Effective anchorage depth $h_{ef}^{1)}$ in AAC cylindrical drill hole	$h_{0,min}=h_{ef,min}$ [mm]	100				
	$h_{0,max}=h_{ef,max}$ [mm]	200				
Effective anchorage depth $h_{ef}^{1)}$ in AAC conical drill hole	$h_0$ [mm]	$h_{ef} + 5$				
	$h_{ef,1}$ [mm]	-	75			-
	$h_{ef,2}$ [mm]	95				
Effective anchorage depth $h_{ef}^{1)}$ in solid brick (depth of drill hole $h_0 = h_{ef}$ )	$h_{ef,min}$ [mm]	50				
	$h_{ef,max}$ [mm]	$h-30, \leq 200$				
Diameter of clearance hole in the fixture	pre-position $d_f \leq$ [mm]	7	9	12	14	18
	push through $d_f \leq$ [mm]	9	11	14	16	20
Diameter of cleaning brush	$d_b \geq$ [mm]	see Table B8.1				
Maximum installation torque	$T_{inst}$ [Nm]	see parameters of brick				

<sup>1)</sup>  $h_{ef,min} \leq h_{ef} \leq h_{ef,max}$  is possible.

**fischer anchor rods M6, M8, M10, M12, M16**



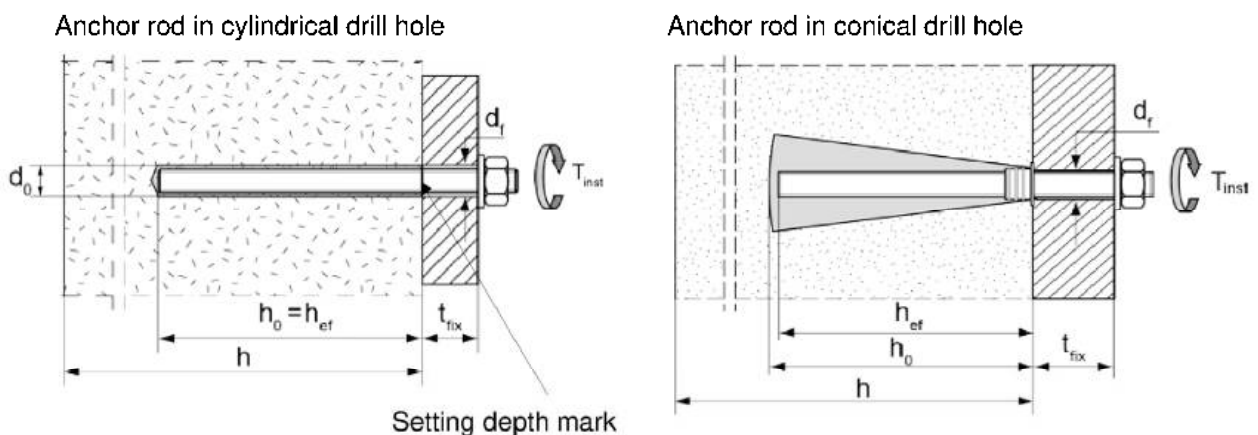
**Marking (on random place) fischer anchor rod:**

Steel zinc plated PC <sup>1)</sup> 8.8	• or +	Steel hot-dip galvanised PC <sup>1)</sup> 8.8	•
High corrosion resistant steel HCR PC <sup>1)</sup> 50	•	High corrosion resistant steel HCR PC <sup>1)</sup> 70	-
High corrosion resistant steel HCR PC <sup>1)</sup> 80	(	Stainless steel R property class 50	~
Stainless steel R property class 80	*		

Alternatively: Colour coding according to DIN 976-1: 2016;  
property class 4.6 marking according to EN ISO 898-1:2013

<sup>1)</sup> PC = property class

**Installation conditions:**



Pictures not to scale

fischer injection system FIS V Plus for masonry

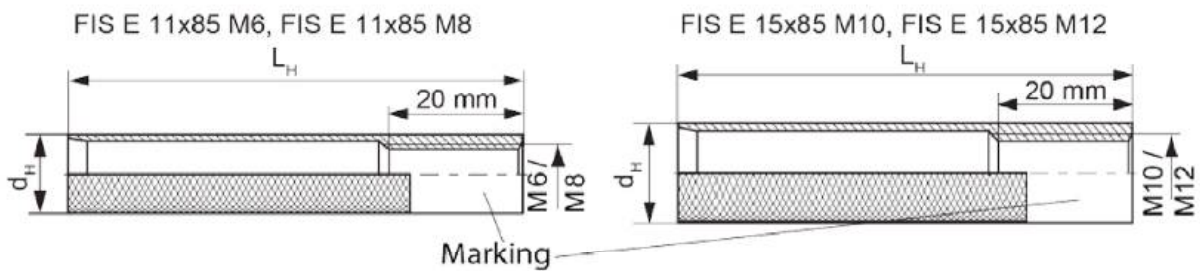
**Intended Use**  
Installation parameters for anchor rods without perforated sleeve

**Annex B 4**

**Table B5.1:** Installation parameters for internal threaded anchors FIS E in solid bricks and autoclaved aerated concrete without perforated sleeves

Internal threaded anchor FIS E		11x85 M6	11x85 M8	15x85 M10	15x85 M12
Diameter of anchor	$d_H$ [mm]	11		15	
Nominal drill hole diameter	$d_0$ [mm]	14		18	
Length of anchor	$L_H$ [mm]	85			
Effective anchorage depth	$h_0 = h_{ef}$ [mm]	85			
Effective anchorage depth $h_{ef}$ in AAC (conical drill hole)	$h_0$ [mm]	100		-	
	$h_{ef}$ [mm]	85			
Diameter of cleaning brush	$d_b \geq$ [mm]	see Table B8.1			
Maximum installation torque	$T_{inst}$ [Nm]	see parameters of brick			
Diameter of clearance hole in the fixture	$d_f$ [mm]	7	9	12	14
Screw-in depth	$l_{E,min}$ [mm]	6	8	10	12
	$l_{E,max}$ [mm]	60			

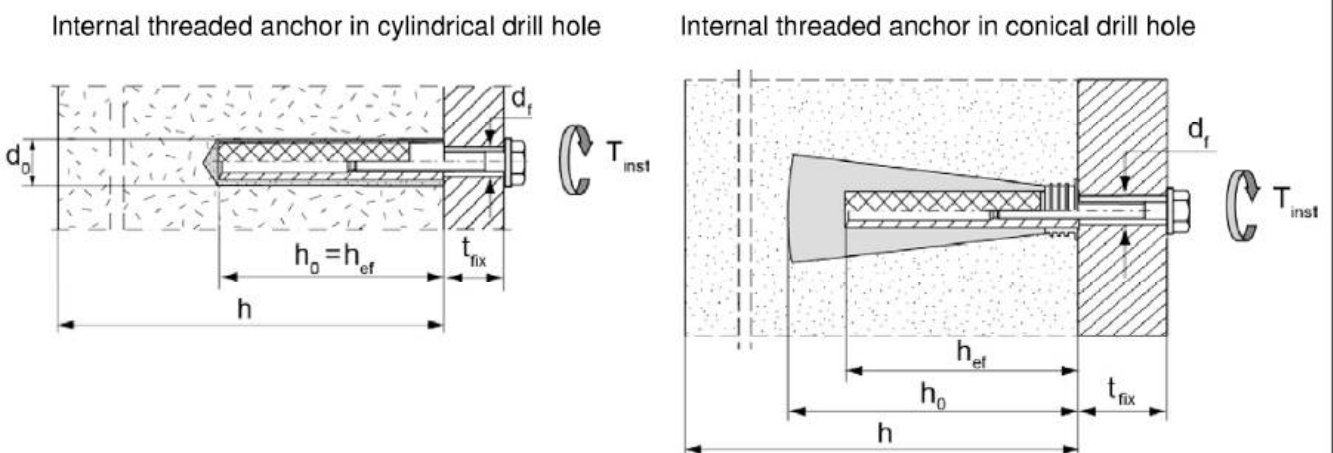
**fischer Internal threaded anchor FIS E**



**Marking:**

Size, e.g. **M8**, Stainless steel: R, e.g. **M8 R**, High corrosion-resistant steel: HCR, e.g. **M8 HCR**

**Installation conditions:**



Pictures not to scale

fischer injection system FIS V Plus for masonry

**Intended Use**

Installation parameters for internal threaded rods FIS E without perforated sleeve

**Annex B 5**

**Table B6.1:** Installation parameters for anchor rods and internal threaded anchors FIS E with perforated sleeves (pre-positioned anchorage)

perforated sleeve FIS H K	12x50	12x85 <sup>2)</sup>	16x85	16x130 <sup>2)</sup>	20x85	20x130 <sup>2)</sup>	20x200 <sup>2)</sup>	
Nominal drill hole diameter $d_0 = D_{\text{sleeve, nom}}$	12		16		20			
Depth of drill hole $h_0$ [mm]	55	90	90	135	90	135	205	
Effective anchorage depth	$h_{\text{ef, min}}$ [mm]	50	65	85	110	85	110	180
	$h_{\text{ef, max}}$ [mm]	50	85	85	130	85	130	200
Size of threaded rod [-]	M6 und M8		M8 und M10		M12 und M16			
Size of internal threaded anchor FIS E	-	-	11x85	-	15x85	-	-	
Diameter of cleaning brush <sup>1)</sup> $d_b \geq$ [mm]	see Table B8.1							
Maximum installation torque $T_{\text{inst}}$ [Nm]	see parameters of brick							

<sup>1)</sup> Only for solid areas in hollow bricks and solid bricks.

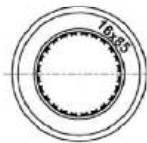
<sup>2)</sup> Bridging of unbearing layer (e.g. plaster) is possible. When reducing the effective anchorage depth  $h_{\text{ef, min}}$ , the values of the next shorter perforated sleeve of the same diameter must be used. The smaller value of characteristic resistance must be taken.

**Perforated sleeve**

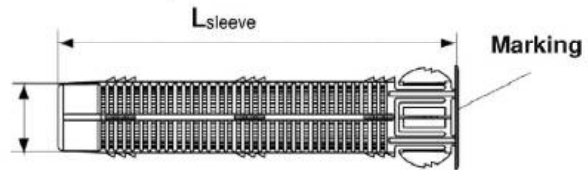
FIS H 12x50 K; FIS H 12x85 K; FIS H 16x85 K; FIS H 16x130 K;  
FIS H 20x85 K; FIS H 20x130 K; FIS H 20x200 K

**Marking:**

Size  $D_{\text{sleeve, nom}}$  X  $L_{\text{sleeve}}$   
(e.g.: 16x85)



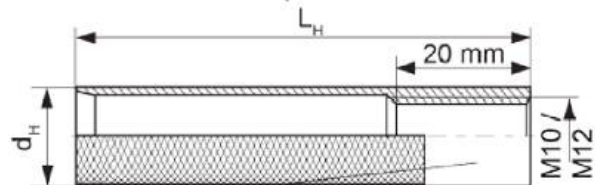
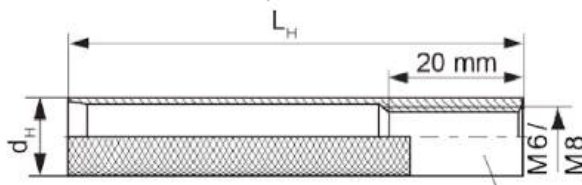
$D_{\text{sleeve, nom}}$



**fischer Internal threaded anchor FIS E**

FIS E 11x85 M6, FIS E 11x85 M8

FIS E 15x85 M10, FIS E 15x85 M12

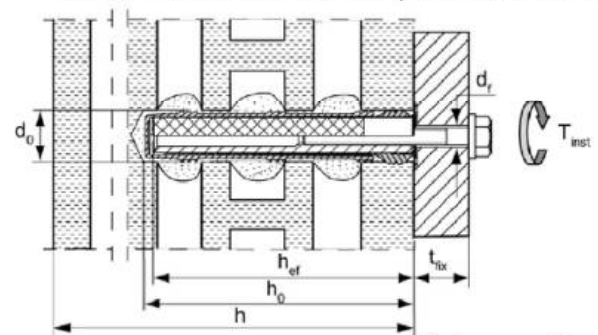
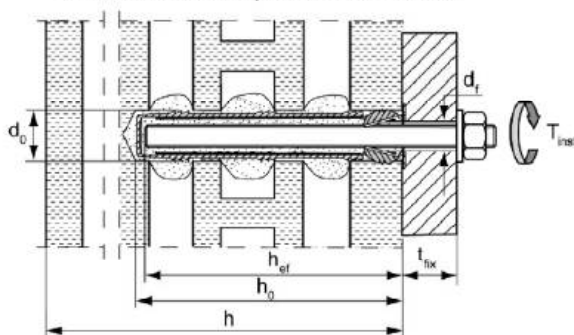


Marking

**Installation conditions:**

Anchor rod with perforated sleeve

Internal threaded anchor with perforated sleeve



Pictures not to scale

fischer injection system FIS V Plus for masonry

**Intended Use**

Installation parameters for anchor rods and internal threaded anchors FIS E with perforated sleeve (pre-positioned anchorage)

**Annex B 6**



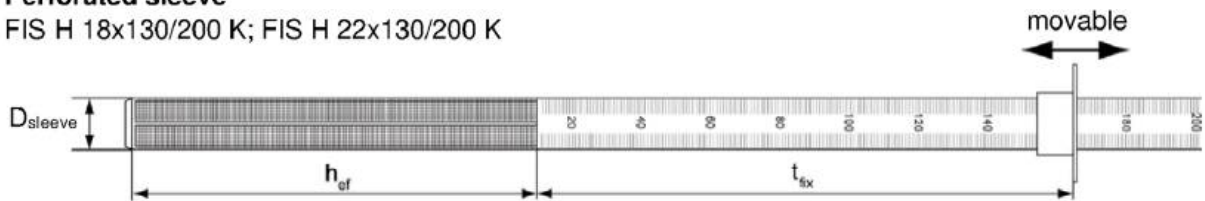
**Table B7.1:** Installation parameters for anchor rods with perforated sleeves (push through anchorage)

Perforated sleeve FIS H K		18x130/200		22x130/200	
Nominal sleeve diameter	$D_{\text{sleeve,nom}}$ [mm]	16		20	
Nominal drill hole diameter	$d_0$ [mm]	18		22	
Depth of drill hole	$h_0$ [mm]	135			
Effective anchorage depth	$h_{\text{ef}}$ [mm]	$\geq 130$			
Diameter of cleaning brush <sup>1)</sup>	$d_b \geq$ [mm]	Siehe Tabelle B8.1			
Size of threaded rod	[-]	M10	M12	M16	
Maximum installation torque	$T_{\text{inst}}$ [Nm]	see parameters of brick			
Thickness of fixture	$t_{\text{fix,max}}$ [mm]	200			

<sup>1)</sup> Only for solid areas in hollow bricks and solid bricks.

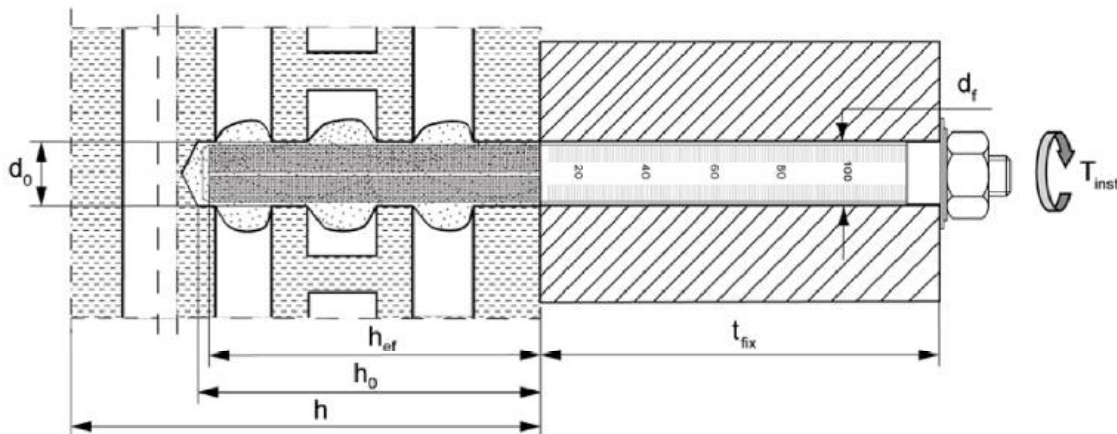
**Perforated sleeve**

FIS H 18x130/200 K; FIS H 22x130/200 K



**Installation conditions:**

Anchor rod with perforated sleeve



Pictures not to scale

fischer injection system FIS V Plus for masonry

**Intended Use**

Installation parameters for anchor rods with perforated sleeves (push through anchorage)

**Annex B 7**

**Tabelle B8.1:** Parameters of the cleaning brush BS (steel brush with steel bristles)

The size of the cleaning brush refers to the drill hole diameter

Drill hole diameter	$d_0$ [mm]	8	10	12	14	16	18	20	22
Brush diameter	$d_b$ [mm]	9	11	14	16	20	20	25	25



Only for solid bricks and autoclaved aerated concrete

**Table B8.2:** Maximum processing times and minimum curing times  
(During the curing time of the mortar the masonry temperature may not fall below the listed minimum temperature)

Temperature at anchoring base [°C]	Maximum processing time $t_{work}$			Minimum curing time $t_{cure}$ <sup>1)</sup>		
	FIS VW Plus High Speed <sup>3)</sup>	FIS V Plus <sup>2)</sup>	FIS VS Plus Low Speed <sup>2)</sup>	FIS VW Plus High Speed <sup>3)</sup>	FIS V Plus <sup>2)</sup>	FIS VS Plus Low Speed <sup>2)</sup>
> 0 to 5	5 min	13 min	20 min	3 h	3 h	6 h
> 5 to 10	3 min	9 min	20 min	50 min	90 min	3 h
> 10 to 20	1 min	5 min	10 min	30 min	60 min	2 h
> 20 to 30	-	4 min	6 min	-	45 min	60 min
> 30 to 40	-	2 min	4 min	-	35 min	30 min

<sup>1)</sup> For wet bricks the curing time must be doubled

<sup>2)</sup> Minimum cartridge temperature +5°C

<sup>3)</sup> Minimum cartridge temperature ±0°C

Pictures not to scale

fischer injection system FIS V Plus for masonry

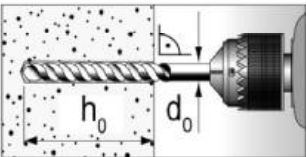
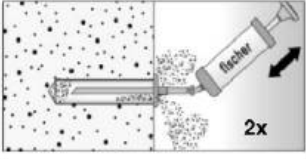
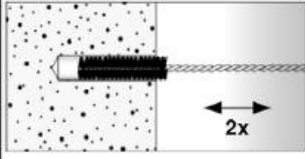
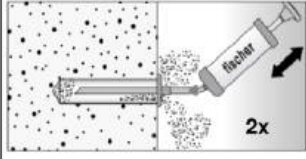
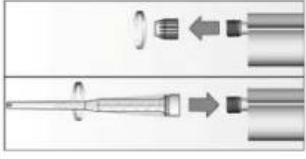


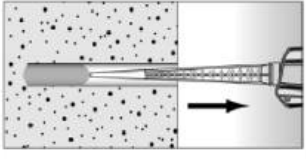
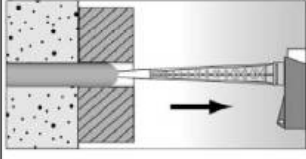
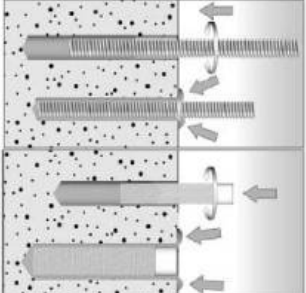

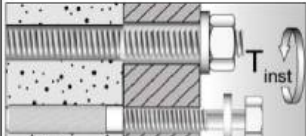
**Intended use**

Cleaning brush (steel brush)  
Maximum processing times and minimum curing times

**Annex B 8**

### Installation instruction part 1

Installation in solid brick and autoclaved aerated concrete (without perforated sleeve)

1		<p>Drill the hole (drilling method see Annex C of the respective brick) depth of drill hole <math>h_0</math> and drill hole diameter <math>d_0</math> see <b>Table B4.1; B5.1</b></p>		
2				<p>Blow out the drill hole twice. Brush twice and blow out twice again.</p>
3		<p>Remove the sealing cap. Screw on the static mixer. (the spiral in the static mixer must be clearly visible)</p>		
4		<p>Place the cartridge into a suitable dispenser</p>		<p>Press out approximately 10 cm of mortar until the resin is permanently grey in colour. Mortar which is not grey in colour will not cure and must be disposed of.</p>
5		<p>Fill approximately 2/3 of the drill hole with mortar beginning from the bottom of the hole<sup>1)</sup>. Avoid bubbles!</p>		<p>For push through anchorage fill the annular clearance with mortar.</p>
6		<p>Only use clean and oil-free metal parts. Mark the anchor rod for setting depth. Insert the anchor rod or internal threaded anchor FIS E by hand using light turning motions. When reaching the setting depth marking, excess mortar must emerge from the mouth of the drill hole.</p>		
7		<p>Do not touch. Minimum curing time see <b>Table B8.2</b></p>		<p>Mounting the fixture. <math>T_{inst}</math> see parameter of brick.</p>

<sup>1)</sup> Exact volume of mortar see manufacturer's specification.

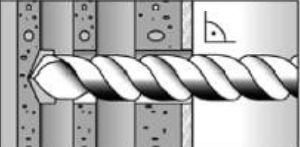
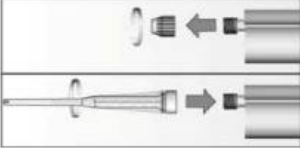


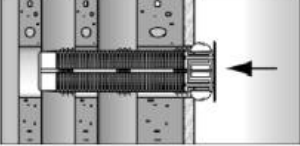
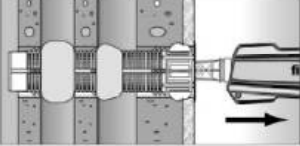
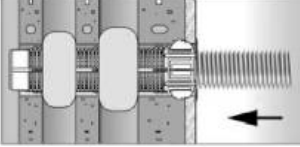

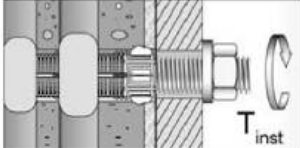
fischer injection system FIS V Plus for masonry

**Intended use**  
Installation instruction (without perforated sleeve) part 1

**Annex B 9**

## Installation instruction part 2

### Installation in perforated or solid brick with perforated sleeve (pre-positioned anchorage)

1		<p>Drill the hole (drilling method see Annex C of the respective brick). depth of drill hole <math>h_0</math> and drill hole diameter <math>d_0</math> see <b>Table B6.1</b></p>	<p>When install perforated sleeves in solid bricks or solid areas of hollow bricks, also clean the hole by blowing out and brushing.</p>
2		<p>Remove the sealing cap. Screw on the static mixer. (the spiral in the static mixer must be clearly visible)</p>	
3		<p>Place the cartridge into a suitable dispenser.</p>	 <p>Press out approximately 10 cm of mortar until the resin is permanently grey in colour. Mortar which is not grey in colour will not cure and must be disposed of.</p>
4		<p>Insert the perforated sleeve flush with the surface of the masonry or plaster.</p>	 <p>Fill the perforated sleeve completely with mortar beginning from the bottom of the hole<sup>1)</sup>.</p>
5		<p>Only use clean and oil-free metal parts. Mark the anchor rod for setting depth. Insert the anchor rod or the internal threaded anchor FIS E by hand using light turning motions until reaching the setting depth marking (anchor rod) or flush with the surface (internal threaded anchor).</p>	
6		<p>Do not touch. Minimum curing time see <b>Table B8.2</b></p>	 <p>Mounting the fixture. <math>T_{inst}</math> see parameter of brick.</p>

<sup>1)</sup> Exact volume of mortar see manufacturer's specification.

fischer injection system FIS V Plus for masonry

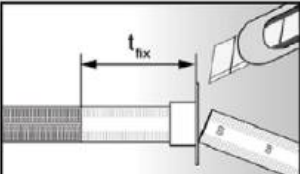
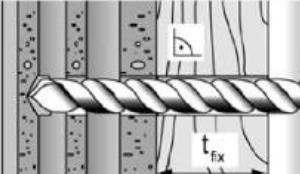
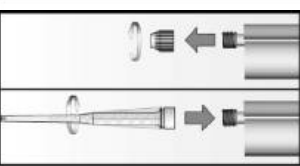
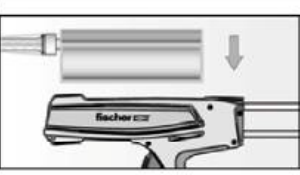

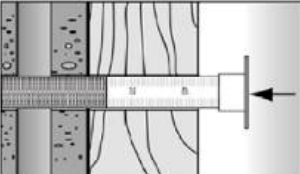
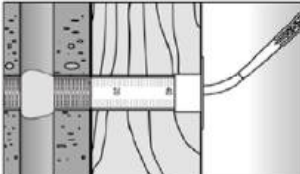
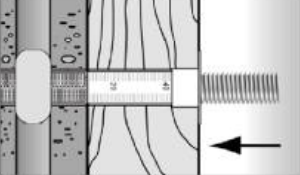

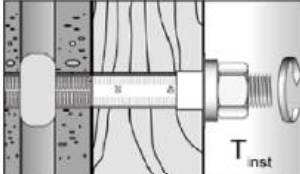
**Intended use**  
Installation instruction (with perforated sleeve) part 2

**Annex B 10**



### Installation instruction part 3

#### Installation in perforated or solid brick with perforated sleeve (push through anchorage)

1		<p>Push the movable stop up to the correct thickness of fixture and cut the overlap.</p>		<p>Drill the hole through the fixture. Depth of drill hole (<math>h_0 + t_{fix}</math>) and drill hole diameter see <b>Table B7.1</b></p>
2		<p>Remove the sealing cap. Screw on the static mixer. (the spiral in the static mixer must be clearly visible)</p>		
3		<p>Place the cartridge into a suitable dispenser.</p>		<p>Press out approximately 10 cm of mortar until the resin is permanently grey in colour. Mortar which is not grey in colour will not cure and must be disposed of.</p>
4		<p>Insert the perforated sleeve flush with the surface of the fixture into the drill hole.</p>		<p>Fill the sleeve with mortar beginning from the bottom of the hole.<sup>1)</sup> For deep drill holes use an extension tube.</p>
5		<p>Only use clean and oil-free metal parts. Mark the anchor rod for setting depth. Insert the anchor rod or the internal threaded anchor FIS E by hand using light turning motions until reaching the setting depth marking (anchor rod) or flush with the surface (internal threaded anchor).</p>		
6		<p>Do not touch. Minimum curing time see <b>Table B8.2</b></p>		<p>Mounting the fixture. <math>T_{inst}</math> see parameter of brick.</p>

<sup>1)</sup> Exact volume of mortar see manufacturer's specification.

fischer injection system FIS V Plus for masonry

**Intended use**  
Installation instruction (with perforated sleeve) part 3

**Annex B 11**



<b>Installation instruction part 4</b>			
<b>Installation in autoclaved aerated concrete with special conic drill bit PBB (pre-positioned anchorage)</b>			
1		Position the movable drill bit arrester on the used drill hole depth (see Annex B 4, Table B4.1) For this, unlock the clamp screw and slide the arrester. Now fix the clamp screw.	
2		Drill the cylindrical hole with rotating drill until the arrester contact the material surface. (drilling method see Annex C of the respective brick)	
3		Deviate the working power drill circulate to generate an conic undercut in the material.	
4		Blow out the drill hole four times.	
5		Remove the sealing cap. Screw on the static mixer. (the spiral in the static mixer must be clearly visible)	
6		Place the cartridge into a suitable dispenser.	
7		Put the center sleeve into the drill hole and adapt the injection adapter onto the static mixer.	
8		Only use clean and oil-free metal parts. Mark the anchor rod for setting depth. Insert the anchor rod or internal threaded anchor FIS E by hand using light turning motions. When reaching the setting depth marking, excess mortar must emerge from the mouth of the drill hole.	
9		Do not touch. Minimum curing time see <b>Table B8.2</b>	
fischer injection system FIS V Plus for masonry			<b>Annex B 12</b>
<b>Intended use</b> Installation instruction for autoclaved aerated concrete with special conic drill bit PBB (pre-positioned anchorage) part 4			

**Table B13.1:** Overview of controlled bricks (part 1)

Kind of masonry	Brick format [mm]	Compressive strength $f_b$ [N/mm <sup>2</sup> ]	Producing country	Density $\rho$ [kg/dm <sup>3</sup> ]	Annex
<b>Solid brick Mz</b>					
Solid brick Mz	NF $\geq 240 \times 115 \times 71$	12 - 20	Germany	$\geq 1,8$	C4 - C7
	2DF $\geq 240 \times 115 \times 113$	10 - 16	Germany	$\geq 1,8$	C8/C9
	$\geq 245 \times 118 \times 54$	10 - 20	Italy	$\geq 1,8$	C10/C11
	$\geq 230 \times 108 \times 55$	10 - 20	Denmark	$\geq 1,8$	C12/C13
<b>Solid sand- lime brick KS / perforated Sand- lime brick KSL</b>					
Solid sand - lime brick KS	NF $\geq 240 \times 115 \times 71$	12 - 28	Germany	$\geq 2,0$	C14/C15
	8DF $\geq 250 \times 240 \times 240$	10 - 28	Germany	$\geq 2,0$	C16/C17
	$\geq 997 \times 214 \times 538$	10 - 36	Netherlands	$\geq 1,8$	C18/C19
Perforated sand - lime brick KSL	3DF $240 \times 175 \times 113$	8 - 20	Germany	$\geq 1,4$	C20 - C23
<b>Vertical perforated brick HLz</b>					
Vertical perforated brick HLz	$370 \times 240 \times 237$	4 - 12	Germany	$\geq 1,0$	C24/C25
	$500 \times 175 \times 237$	4 - 12	Germany	$\geq 1,0$	C24/C25
	2DF $240 \times 115 \times 113$	6 - 28	Germany	$\geq 1,4$	C26/C27
	$248 \times 365 \times 248$	4 - 8	Germany	$\geq 0,6$	C28 - C31
	$248 \times 365 \times 249$	8 - 12	Germany	$\geq 0,7$	C32 - C35
	$248 \times 365 \times 249$	4 - 6	Germany	$\geq 0,5$	C36 - C39
	$248 \times 425 \times 248$	4 - 8	Germany	$\geq 0,8$	C40 - C43
	$248 \times 425 \times 248$	4 - 8	Germany	$\geq 0,6$	C44 - C47
	$500 \times 200 \times 315$	4 - 8	France	$\geq 0,6$	C48 - C51
	$500 \times 200 \times 300$	4 - 10	France	$\geq 0,7$	C52 - C55
	$500 \times 200 \times 315$	2 - 8	France	$\geq 0,7$	C56 - C59
	$560 \times 200 \times 275$	4 - 8	France	$\geq 0,7$	C60/C61
	$255 \times 120 \times 118$	2 - 12	Italy	$\geq 1,0$	C62 - C64
	$275 \times 130 \times 94$	6 - 20	Spain	$\geq 0,8$	C65/C66
	$220 \times 190 \times 290$	6 - 10	Portugal	$\geq 0,7$	C67 - C70
	$253 \times 300 \times 240$	2 - 6	Austria	$\geq 0,8$	C71 - C74
	$250 \times 440 \times 250$	6 - 10	Austria	$\geq 0,7$	C75 - C78
	$230 \times 108 \times 55$	2 - 8	Denmark	$\geq 1,4$	C79/C80
<b>Horizontal perforated brick LLz</b>					
Horizontal perforated brick LLz	$248 \times 78 \times 250$	2 - 6	Italy	$\geq 0,7$	C81/C82
	$128 \times 88 \times 275$	2	Spain	$\geq 0,8$	C83/C84
<b>Light-weight concrete hollow block Hbl</b>					
Light-weight concrete hollow block Hbl	$362 \times 240 \times 240$	2 - 4	Germany	$\geq 1,0$	C85 - C88
	$500 \times 200 \times 200$	2 - 6	France	$\geq 1,0$	C89/C90
	$440 \times 215 \times 215$	4 - 10	Ireland	$\geq 1,2$	C91 - C94
fischer injection system FIS V Plus for masonry				<b>Annex B 13</b>	
Intended use Overview of controlled bricks (part 1)					

**Table B14.1:** Overview of controlled bricks (part 2)

Kind of masonry	Brick format [mm]	Compressive strength $f_b$ [N/mm <sup>2</sup> ]	Producing country	Density $\rho$ [kg/dm <sup>3</sup> ]	Annex
<b>Light-weight concrete solid block Vbl</b>					
<b>Light-weight concrete solid block Vbl</b>	≥ 372x300x254	2	Germany	≥0,6	C95/C96
	≥ 250x240x239	4 - 8	Germany	≥1,6	C97 - C100
	≥ 440x100x215	4 - 10	Ireland	≥2,0	C101/C102
	≥ 440x95x215	6 - 12	England	≥2,0	C103/C104
<b>Autoclaved aerated concrete (AAC)</b>					
<b>PP2 / AAC</b>	-	2	Germany	0,35	C105 - C109
<b>PP4 / AAC</b>	-	4	Germany	0,5	C105 - C109
<b>PP6 / AAC</b>	-	6	Germany	0,65	C105 - C109

fischer injection system FIS V Plus for masonry

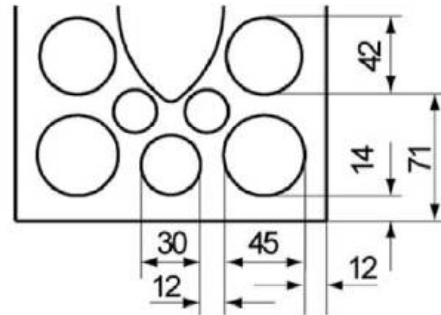
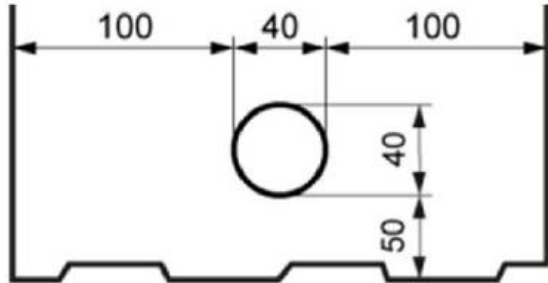
**Intended use**  
Overview of controlled bricks (part 2)

**Annex B 14**

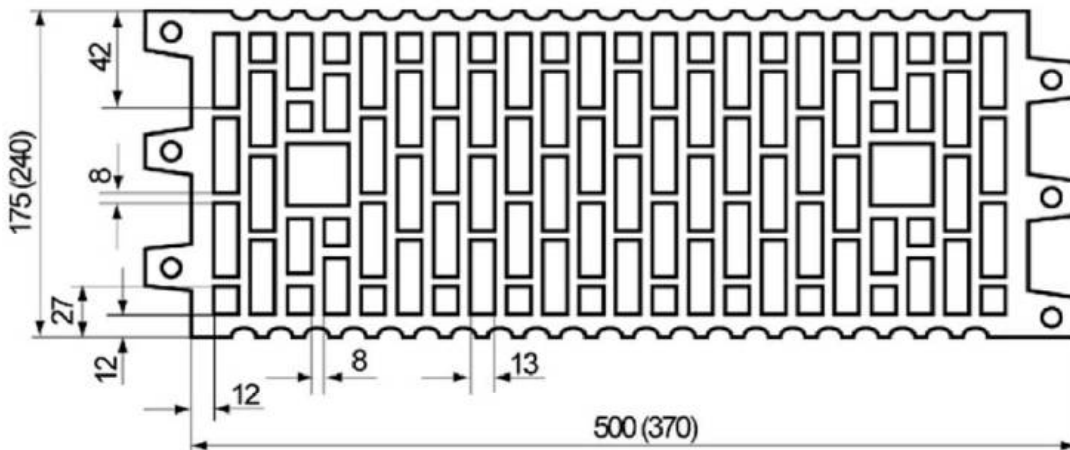
**Table B15.1: Overview dimensions of perforated and hollow bricks (part 1)**

Solid sand-lime brick KS, 8DF, EN 771-2:2015 according to Annex C 16

Perforated sand-lime brick KSL, 3DF, EN 771-2:2015; e.g. KS Wemding according to Annex C 20

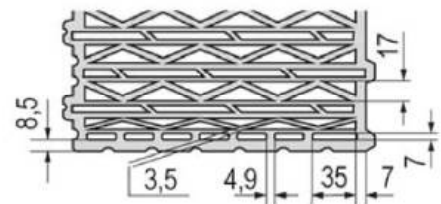
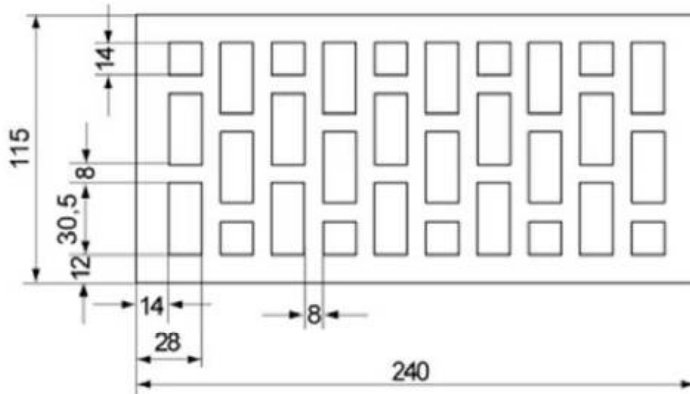


Vertical perforated brick HLz, EN 771-1:2015; e.g. Wienerberger, Poroton according to Annex C 24



Vertical perforated brick HLz, 2DF, EN 771-1:2015; e.g. Wienerberger according to Annex C 26

Vertical perforated brick HLz, T8, EN 771-1:2015; according to Annex C 28



Pictures not to scale

fischer injection system FIS V Plus for masonry

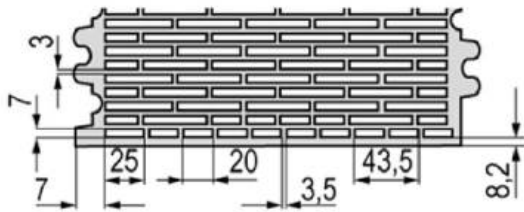
**Intended use**  
Overview dimensions of perforated and hollow bricks (part 1)

**Annex B 15**

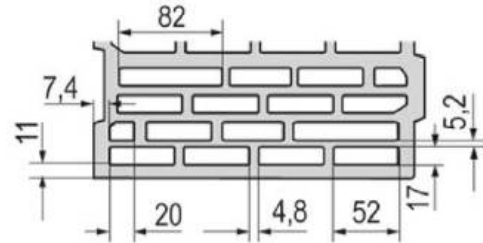


**Table B16.1: Overview dimensions of perforated and hollow bricks (part 2)**

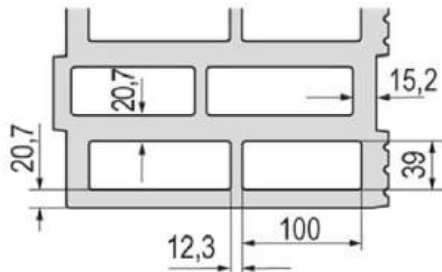
Vertical perforated brick HLz, T10, T11, EN 771-1:2015; according to Annex C32



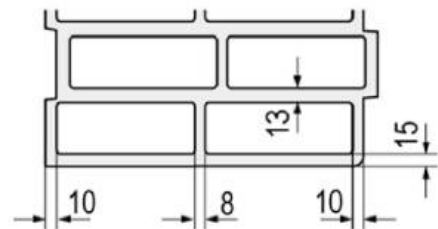
Vertical perforated brick HLz, T7 PF, filled with perlite, EN 771-1:2015; according to Annex C 36



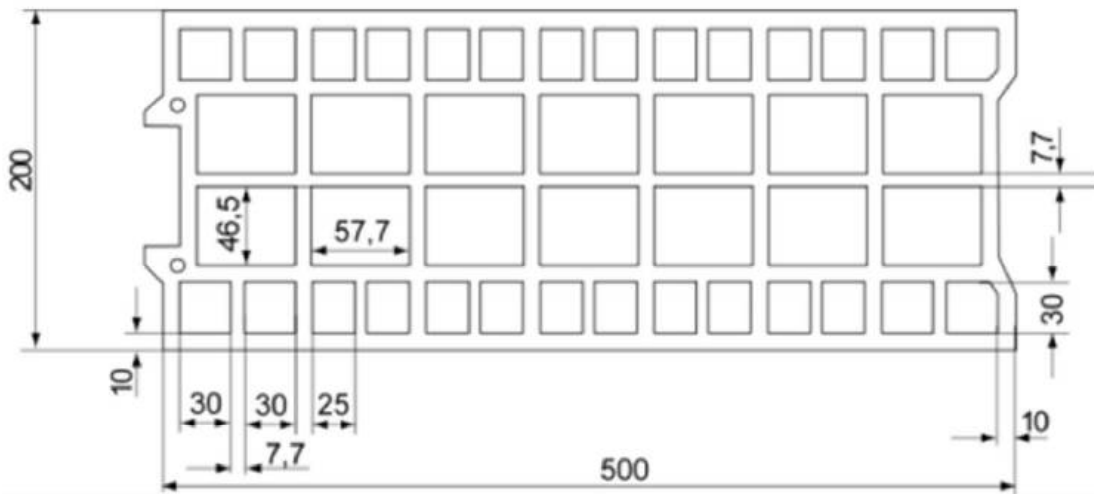
Vertical perforated brick HLz, S9 MW, filled with mineral wool, EN 771-1:2015; according to Annex C 40



Vertical perforated brick HLz, T7 MW, filled with mineral wool, EN 771-1:2015; according to Annex C 44



Vertical perforated brick HLz, EN 771-1:2015; e.g. Bouyer Leroux; According to Annex C 48



Pictures not to scale

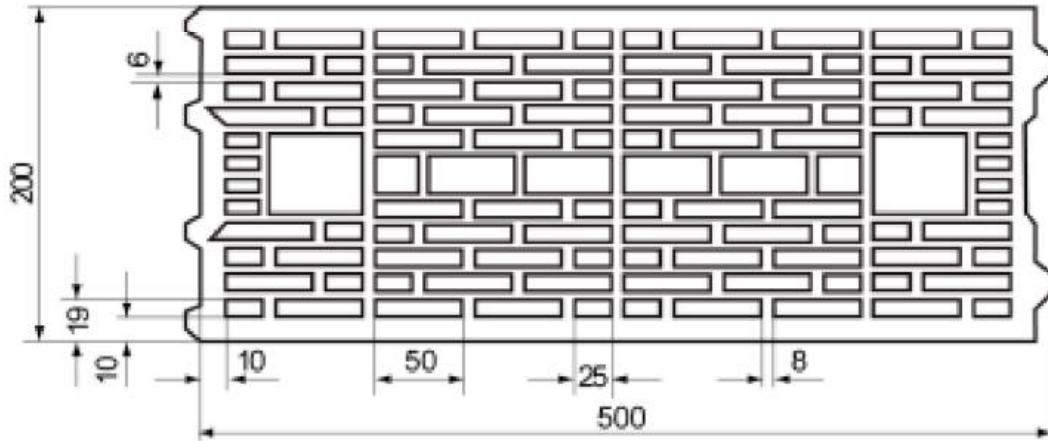
fischer injection system FIS V Plus for masonry

**Intended use**  
Overview dimensions of perforated and hollow bricks (part 2)

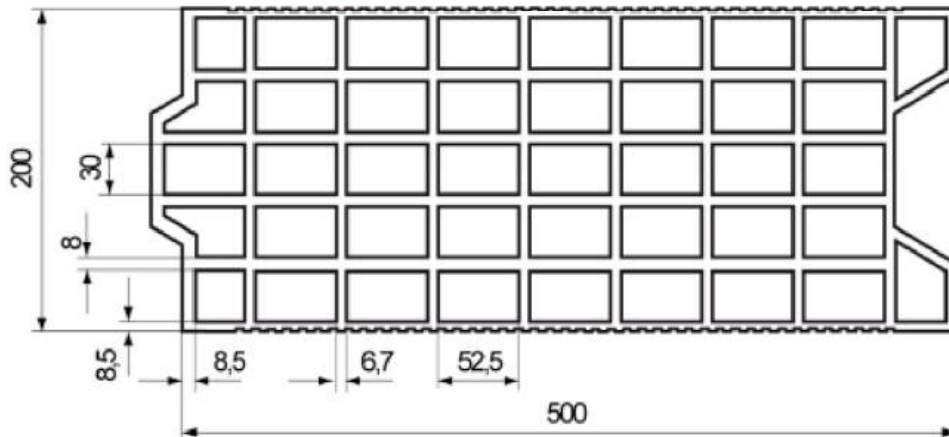
**Annex B 16**

**Table B17.1:** Overview dimensions of perforated and hollow bricks (part 3)

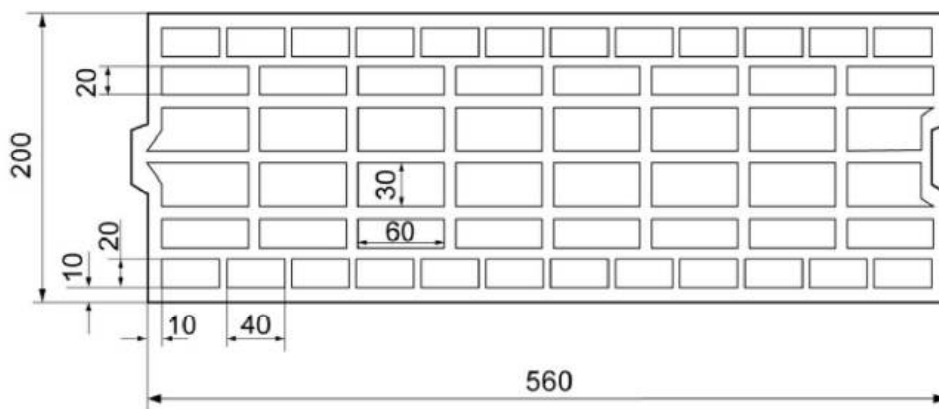
Vertical perforated brick HLz, EN 771-1:2015; e.g. Wienerberger according to Annex C 52



Vertical perforated brick HLz, EN 771-1:2015; e.g. Terreal according to Annex C 56



Vertical perforated brick HLz, EN 771-1:2015; e.g. Imery according to Annex C 60



Pictures not to scale

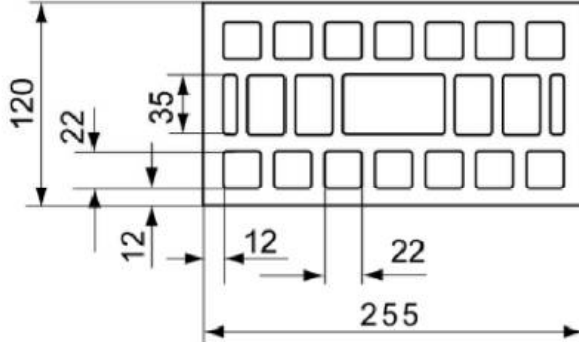
fischer injection system FIS V Plus for masonry

**Intended use**  
Overview dimensions of perforated and hollow bricks (part 3)

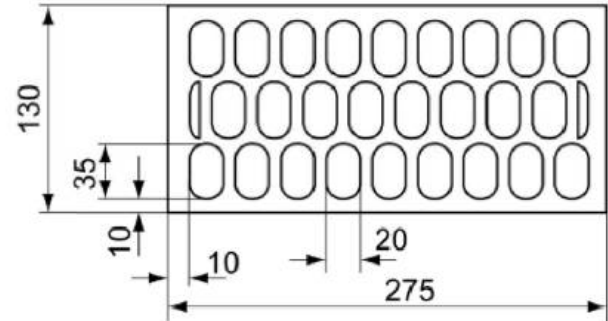
**Annex B 17**

**Table B18.1: Overview dimensions of perforated and hollow bricks (part 4)**

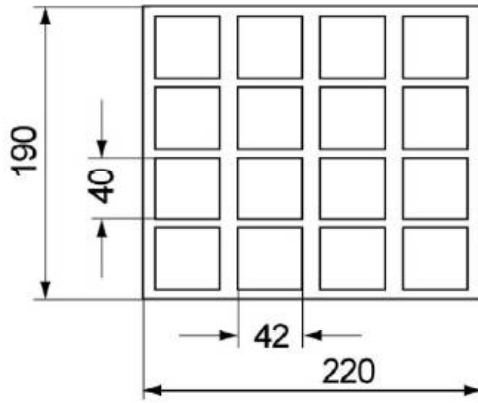
Vertical perforated brick HLz, EN 771-1:2015;  
e.g. Wienerberger according to Annex C 62



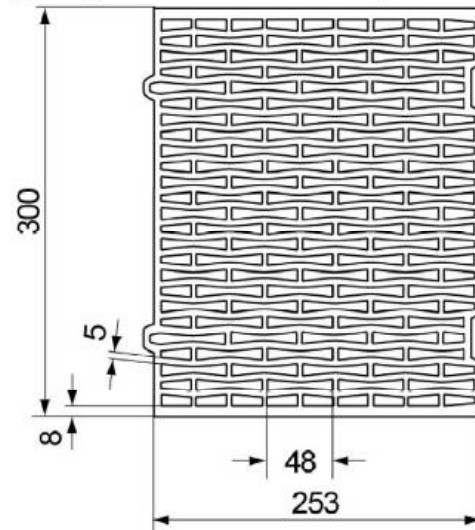
Vertical perforated brick HLz, EN 771-1:2015;  
e.g. Germanica Farreny S.A. according to Annex C 65



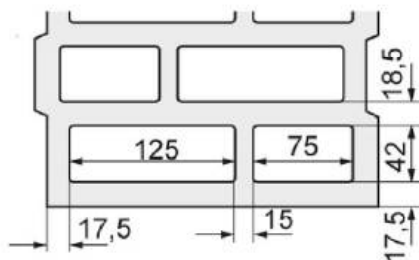
Vertical perforated brick HLz, EN 771-1:2015;  
e.g. Perceram according to Annex C 67



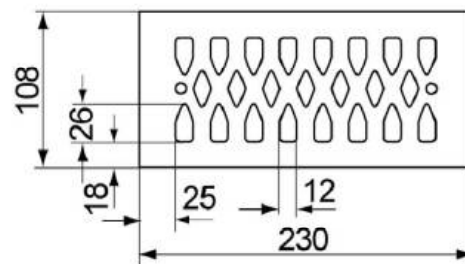
Vertical perforated brick HLz, EN 771-1:2015;  
e.g. Ziegelwerk Brenna according to Annex C 71



Vertical perforated brick HLz, Porotherm W 44, filled  
with mineral wool, EN 771-1:2015 according to  
Annex C 75



Vertical perforated brick HLz, EN 771-1:2015;  
e.g. Wienerberger according to Annex C 79



Pictures not to scale

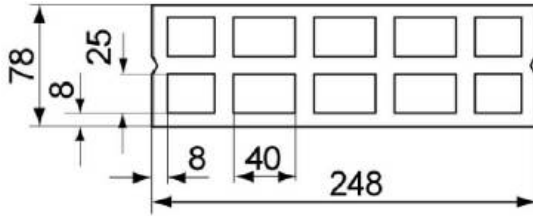
fischer injection system FIS V Plus for masonry

**Intended use**  
Overview dimensions of perforated and hollow bricks (part 4)

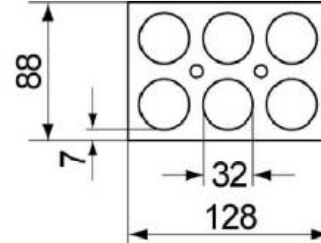
**Annex B 18**

**Table B19.1: Overview dimensions of perforated and hollow bricks (part 5)**

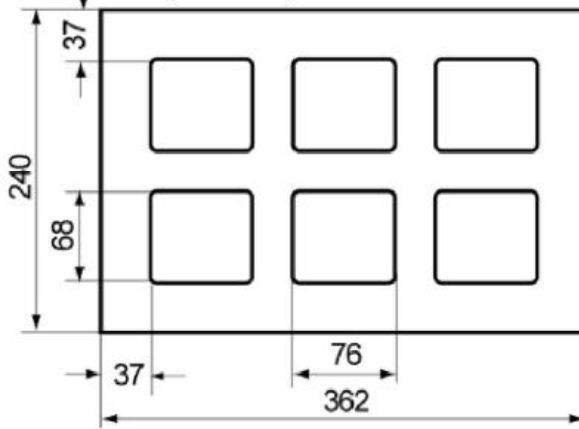
Horizontal perforated brick LLz, EN 771-1:2015; according to Annex C 81



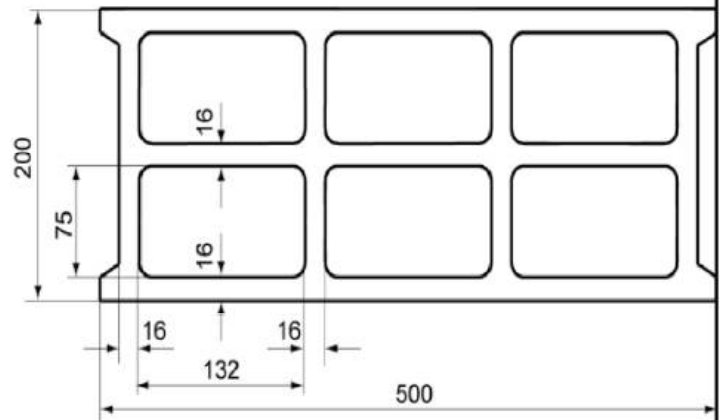
Horizontal perforated brick LLz, EN 771-1:2015; e.g. Germanica Farreny S.A according to Annex C 83



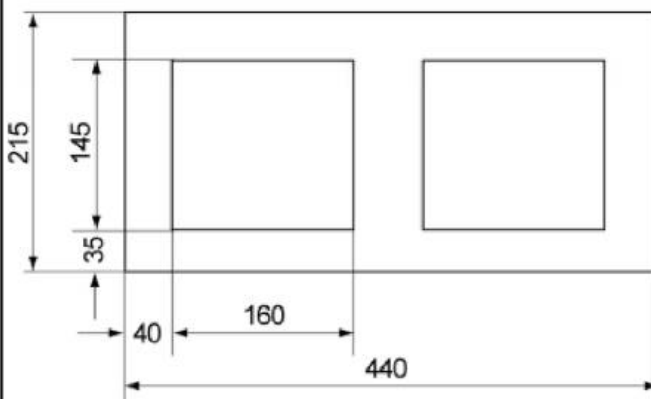
Light-weight concrete hollow block Hbl, EN 771-3:2015; according to Annex C 85



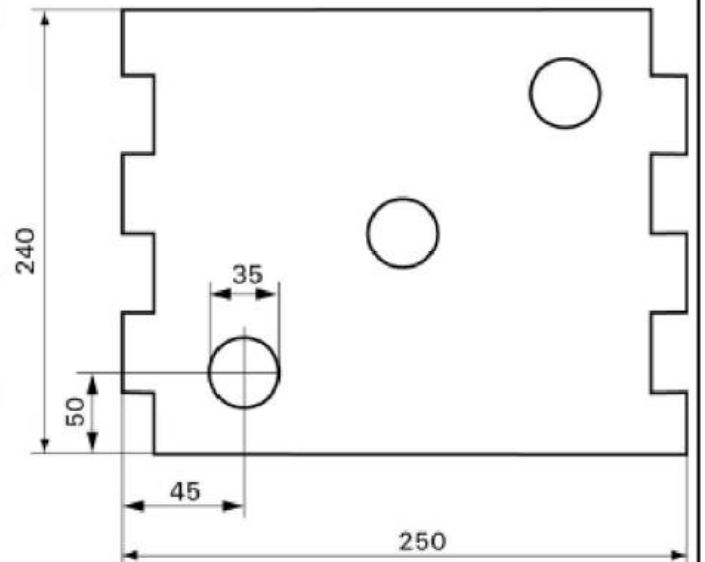
Light-weight concrete hollow block Hbl, EN 771-3:2015; e.g. Sepa according to Annex C 89



Light-weight concrete hollow block Hbl, EN 771-3:2015; e.g. Roadstone wood according to Annex C 91



Light-weight concrete solid block Vbl, EN 771-3:2015; e.g. Sepa according to Annex C 97



Pictures not to scale

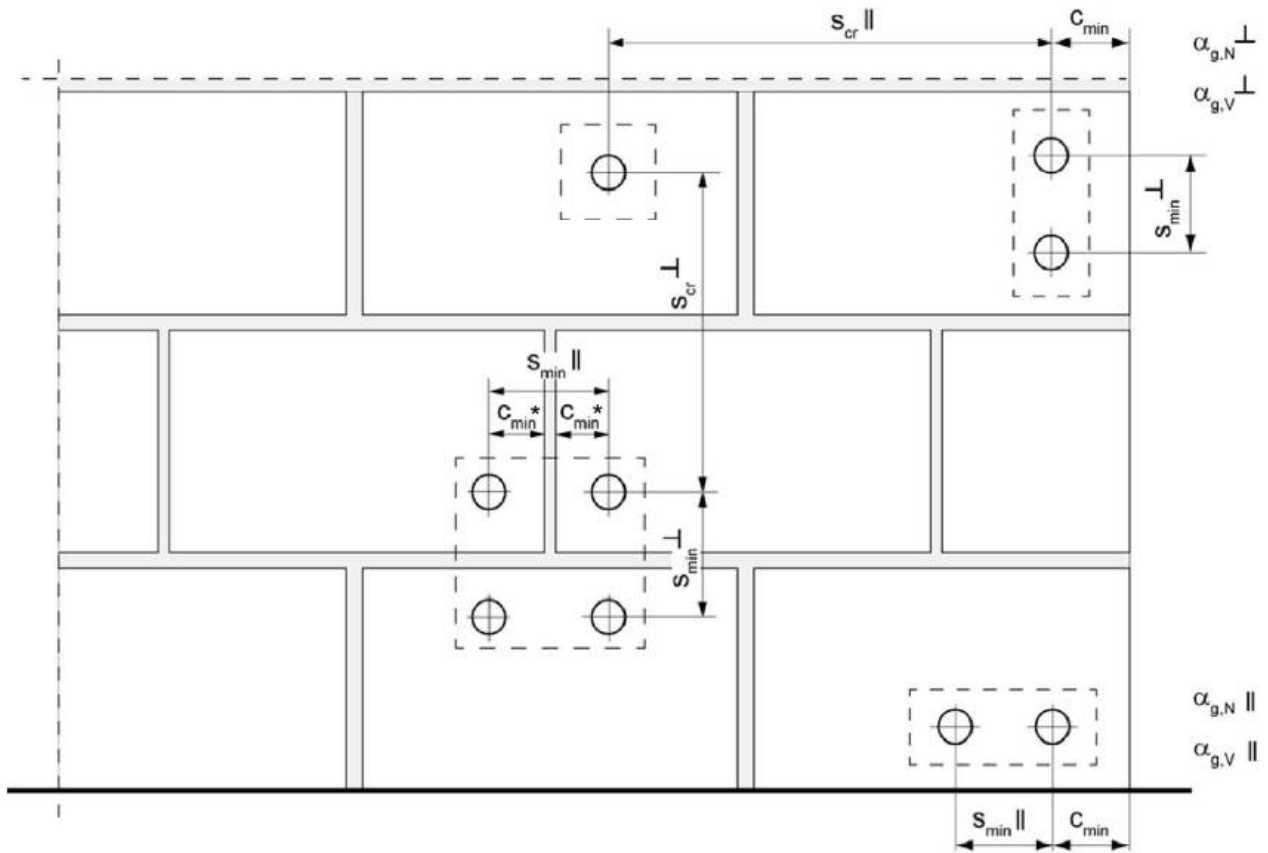
fischer injection system FIS V Plus for masonry

**Intended use**  
Overview dimensions of perforated and hollow bricks (part 5)

**Annex B 19**



## Spacing and edge distance



\* Only, if vertical joints are not completely filled with mortar

- $s_{min \parallel}$  = Minimum spacing parallel to bed joint
- $s_{min \perp}$  = Minimum spacing vertical to bed joint
- $s_{cr \parallel}$  = Characteristic spacing parallel to bed joint
- $s_{cr \perp}$  = Characteristic spacing vertical to bed joint
- $C_{cr} = C_{min}$  = Edge distance
- $\alpha_{g,N \parallel}$  = Group factor for tension resistance, anchor group parallel to bed joint
- $\alpha_{g,V \parallel}$  = Group factor for shear resistance, anchor group parallel to bed joint
- $\alpha_{g,N \perp}$  = Group factor for tension resistance, anchor group vertical to bed joint
- $\alpha_{g,V \perp}$  = Group factor for shear resistance, anchor group vertical to bed joint

For  $s \geq s_{cr}$   $\alpha_g = 2$

For  $s_{min} \leq s < s_{cr}$   $\alpha_g$  according to installation parameters of brick

$N^{gRk} = \alpha_{g,N} \cdot N_{Rk}$  ;  $V^{gRk} = \alpha_{g,V} \cdot V_{Rk}$  (Group of 2 anchors)

$N^{gRk} = \alpha_{g,N \parallel} \cdot \alpha_{g,N \perp} \cdot N_{Rk}$  ;  $V^{gRk} = \alpha_{g,V \parallel} \cdot \alpha_{g,V \perp} \cdot V_{Rk}$  (Group of 4 anchors)

fischer injection system FIS V Plus for masonry

**Intended use**  
Spacing and edge distance

**Annex B 20**

**Table C1.1:** Characteristic values for the **resistance to steel failure of anchor rods** under tension load

Anchor rod		M6	M8	M10	M12	M16		
<b>Resistance under tension load, steel failure</b>								
Characteristic resistance $N_{Rk,s}$	Steel zinc plated	4.6	8	15(13) <sup>3)</sup>	23(21) <sup>3)</sup>	33	63	
		4.8	8	15(13) <sup>3)</sup>	23(21) <sup>3)</sup>	33	63	
		5.8	10	19(17) <sup>3)</sup>	29(27) <sup>3)</sup>	43	79	
		8.8	16	29(27) <sup>3)</sup>	47(43) <sup>3)</sup>	68	126	
	Stainless steel R and High corrosion resistant steel HCR	Property class	50	10	19	29	43	79
			70	14	26	41	59	110
			80	16	30	47	68	126
<b>Partial factors <sup>1)</sup></b>								
Partial factor $\gamma_{Ms,N}$	Steel zinc plated	Property class	4.6	[-]	2,00			
					1,50			
					1,50			
					1,50			
	Stainless steel R and High corrosion resistant steel HCR	Property class	50	[-]	2,86			
					1,50 <sup>2)</sup> / 1,87			
					1,60			

<sup>1)</sup> In absence of other national regulations

<sup>2)</sup> Only for fischer FIS A made of high corrosion-resistant steel HCR

<sup>3)</sup> Values in brackets are valid for undersized threaded rods with smaller stress area  $A_s$  for hot dip galvanised standard threaded rods according to EN ISO 10684:2004+AC:2009

fischer injection system FIS V Plus for masonry

**Performance**  
Characteristic resistance to steel failure of anchor rods under tension load

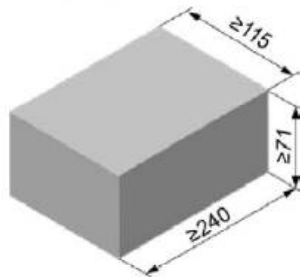
**Annex C 1**

**Table C2.1:** Characteristic values for the **resistance to steel failure of anchor rods** under shear load

Anchor rod		M6	M8	M10	M12	M16		
<b>Resistance under shear load, steel failure</b>								
<b>without lever arm</b>								
Characteristic resistance $V_{Rk,s}$	Steel zinc plated	4.6	[kN]	4	9(8) <sup>3)</sup>	14(13) <sup>3)</sup>	20	38
		4.8		4	9(8) <sup>3)</sup>	14(13) <sup>3)</sup>	20	38
	5.8	6		11(10) <sup>3)</sup>	17(16) <sup>3)</sup>	25	47	
	8.8	8		15(13) <sup>3)</sup>	23(21) <sup>3)</sup>	34	63	
	Stainless steel R and High corrosion resistant steel HCR	50		5	9	15	21	39
		70		7	13	20	30	55
80	8	15	23	34	63			
<b>with lever arm</b>								
Characteristic resistance $M^0_{Rk,s}$	Steel zinc plated	4.6	[Nm]	6	15(13) <sup>3)</sup>	30(27) <sup>3)</sup>	52	133
		4.8		6	15(13) <sup>3)</sup>	30(27) <sup>3)</sup>	52	133
	5.8	7		19(16) <sup>3)</sup>	37(33) <sup>3)</sup>	65	166	
	8.8	12		30(26) <sup>3)</sup>	60(53) <sup>3)</sup>	105	266	
	Stainless steel R and High corrosion resistant steel HCR	50		7	19	37	65	166
		70		10	26	52	92	232
80	12	30	60	105	266			
<b>Partial factors<sup>1)</sup></b>								
Partial factor $\gamma_{Ms,V}$	Steel zinc plated	4.6	[-]	1,67				
		4.8		1,25				
	5.8	1,25						
	8.8	1,25						
	Stainless steel R and High corrosion resistant steel HCR	50		2,38				
		70		1,25 <sup>2)</sup> / 1,56				
80	1,33							
<p>1) In absence of other national regulations</p> <p>2) Only for fischer FIS A made of high corrosion-resistant steel HCR</p> <p>3) Values in brackets are valid for undersized threaded rods with smaller stress area <math>A_s</math> for hot dip galvanised standard threaded rods according to EN ISO 10684:2004+AC:2009.</p>								
fischer injection system FIS V Plus for masonry						<b>Annex C 2</b>		
<b>Performance</b> Characteristic resistance to steel failure of anchor rods under shear load								

<b>Table C3.1: Characteristic values for the resistance to steel failure of internal threaded anchors FIS E under tension / shear load</b>								
<b>fischer internal threaded anchor FIS E</b>				<b>M6</b>	<b>M8</b>	<b>M10</b>	<b>M12</b>	
<b>Resistance under tension load, steel failure</b>								
Characteristic resistance with screw	$N_{Rk,s}$	Property class	5.8	[kN]	10	18	29	42
		Property class 70	R		14	26	41	59
			HCR		14	26	41	59
<b>Partial factors<sup>1)</sup></b>								
Partial factor	$\gamma_{Ms,N}$	Property class	5.8	[-]	1,50			
		Property class 70	R		1,87			
			HCR		1,87			
<b>Resistance under shear load, steel failure</b>								
<b>without lever arm</b>								
Characteristic resistance with screw	$V_{Rk,s}$	Property class	5.8	[kN]	5	9	15	21
		Property class 70	R		7	13	20	30
			HCR		7	13	20	30
<b>with lever arm</b>								
Characteristic resistance	$M^0_{Rk,s}$	Property class	5.8	[Nm]	8	19	37	65
		Property class 70	R		11	26	52	92
			HCR		11	26	52	92
<b>Partial factors<sup>1)</sup></b>								
Partial factor	$\gamma_{Ms,v}$	Property class	5.8	[-]	1,25			
		Property class 70	R		1,56			
			HCR		1,56			
<sup>1)</sup> In absence of other national regulations								
fischer injection system FIS V Plus for masonry							<b>Annex C 3</b>	
<b>Performance</b> Characteristic resistance to steel failure of fischer internal threaded anchor FIS E								

**Solid brick Mz, NF, EN 771-1:2015**



Solid brick Mz, NF, EN 771-1:2015			
Producer	e.g. Wienerberger		
Nominal dimensions [mm]	length L	width W	height H
	≥ 240	≥ 115	≥ 71
Density $\rho$ [kg/dm <sup>3</sup> ]	≥ 1,8		
Compressive strength $f_b$ [N/mm <sup>2</sup> ]	12 / 20		
Standard or annex	EN 771-1:2015		

**Table C4.1:** Installation parameters for edge distance  $c=100\text{mm}$

Anchor rod		M6	M8	M10	M12	-	-	
Internal threaded anchor FIS E		-	-	-	-	M6 11x85	M8 M10 M12 15x85	
Anchor rod and internal threaded anchor FIS E without perforated sleeve								
Effective anchorage depth $h_{ef}$	[mm]	50	50	50	50	85		
		80	80	80	80			
		200	200	200	200			
Max. installation torque $T_{inst}$	[Nm]	4	10		4	10		
General installation parameters								
Edge distance $c_{min}$	[mm]	100				100		
Edge distance $h_{ef}=200$		150				- <sup>1)</sup>		
Spacing		$s_{min II,N}$	60				60	
		$h_{ef}=200 s_{min II,N}$	240				- <sup>1)</sup>	
		$s_{min II,V}$	240				240	
		$s_{cr II}$	240				240	
		$s_{cr \perp} = s_{min \perp}$	75				75	
Drilling method								
Hammer drilling with hard metal hammer drill								

<sup>1)</sup> No performance assessed

**Table C4.2:** Group factors

Anchor rods		M6	M8	M10	M12	-	-
Internal threaded anchor FIS E		-	-	-	-	M6 11x85	M8 M10 M12 15x85
Edge distance $c_{min}$	[mm]	100					
Group factor	$\alpha_{g,N II}$	1,5					
	$\alpha_{g,V II}$	2,0					
	$h_{ef}=200 \alpha_{g,N II}$	1,5					
	$h_{ef}=200 \alpha_{g,V II}$	2,0					
	$\alpha_{g,N \perp}$	2,0					
	$\alpha_{g,V \perp}$	2,0					
	$h_{ef}=200 \alpha_{g,N \perp}$	2,0					
	$h_{ef}=200 \alpha_{g,V \perp}$	2,0					

fischer injection system FIS V Plus for masonry

**Performance**  
Solid brick Mz, NF, dimensions, installation parameters  $c=100\text{mm}$

**Annex C 4**

**Solid brick Mz, NF, EN 771-1:2015**

**Table C5.1:** Characteristic resistance under tension load for edge distance  $c=100\text{mm}$

Anchor rod		M6	M8	M10			M12			-		-	
Internal threaded anchor FIS E		-	-	-			-			M6	M8	M10	M12
										11x85		15x85	
<b><math>N_{Rk} = N_{Rk,p} = N_{Rk,b}</math> [kN] depending on the compressive strength <math>f_b</math> (temperature range 50/80°C)</b>													
compressive strength $f_b$	use categorie		Effective anchorage depth $h_{ef}$ [mm]								85		
	$\geq 50$	$\geq 50$	50	80	200	50	80	200	85				
12N/mm <sup>2</sup>	w/w	w/d	2,5	2,5	2	3	7,5	2	3,5	5	3,5		
	d/d		4	4	3,5	5	12	3	5,5	8	5,5		
20N/mm <sup>2</sup>	w/w	w/d	3,5	3,5	3	4,5	11	3	5	7	5		
	d/d		5,5	5,5	5	7	12	4,5	8	11,5	8		

Factor for temperature range 72/120°C: 0,83

**Table C5.2:** Characteristic resistance under shear load for edge distance  $c=100\text{mm}$

Anchor rod		M6	M8	M10			M12			-		-	
Internal threaded anchor FIS E		-	-	-			-			M6	M8	M10	M12
										11x85		15x85	
<b><math>V_{Rk} = V_{Rk,b} = V_{Rk,c}</math> [kN] depending on the compressive strength <math>f_b</math> (temperature range 50/80°C and 72/120°C)</b>													
compressive strength $f_b$	use categorie		Effective anchorage depth $h_{ef}$ [mm]								85		
	$\geq 50$	$\geq 50$	$\geq 50$	200	$\geq 50$	200	85						
12N/mm <sup>2</sup>	w/w	w/d	2,5	2,5	4	8,5	4	11,5	2,5				
	d/d												
20N/mm <sup>2</sup>	w/w	w/d	4,0	4,0	6	12	5,5	12	4				
	d/d												

Factor for job site tests and displacements see annex C110

fischer injection system FIS V Plus for masonry

**Performance**

Solid brick Mz, NF, Characteristic resistance under tension and shear load  $c=100\text{mm}$

**Annex C 5**

### Solid brick Mz, NF, EN 771-1:2015

**Table C6.1:** Installation parameters for edge distance  $c=60\text{mm}$

Anchor rod		M6	M8	M10	M12	M16	-		-		
Internal threaded anchor FIS E		-	-	-	-	-	M6	M8	M10	M12	
						11x85		15x85			
<b>Anchor rod and internal threaded anchor FIS E without perforated sleeve</b>											
Effective anchorage depth	$h_{ef}$ [mm]	50	50	50	50	50	85				
		100	100	100	100	100					
		200	200	200	200	200					
Max. installation torque	$T_{inst}$ [Nm]	4	10				4	10			
<b>General installation parameters</b>											
Edge distance	$c_{min}$					60					
Edge distance $h_{ef}=200$	$c_{min}$					60					
Spacing	$s_{min II,N}$					80					
	$h_{ef}=200$ $s_{min II,N}$					80					
	$s_{min II,V}$					80					
	$s_{cr II}$					$3x h_{ef}$					
	$s_{min \perp}$					80					
	$s_{cr \perp}$					$3x h_{ef}$					
<b>Drilling method</b>											
Hammer drilling with hard metal hammer drill											

**Table C6.2:** Group factors

Anchor rods		M6	M8	M10	M12	M16	-		-	
Internal threaded anchor FIS E		-	-	-	-	-	M6	M8	M10	M12
						11x85		15x85		
Edge distance	$c_{min}$ [mm]					60				
Group factor	$\alpha_{g,N II}$					0,6				
	$\alpha_{g,V II}$					1,3				
	$h_{ef}=200$ $\alpha_{g,N II}$					1,4				
	$h_{ef}=200$ $\alpha_{g,V II}$					1,5				
	$\alpha_{g,N \perp}$					0,3				
	$\alpha_{g,V \perp}$					1,3				
	$h_{ef}=200$ $\alpha_{g,N \perp}$					2,0				
	$h_{ef}=200$ $\alpha_{g,V \perp}$					1,1				

fischer injection system FIS V Plus for masonry

**Performance**  
Solid brick Mz, NF, dimensions, installation parameters  $c=60\text{mm}$

**Annex C 6**



**Solid brick Mz, NF, EN 771-1:2015**

**Table C7.1:** Characteristic resistance under tension load for edge distance  $c=60\text{mm}$

Anchor rod	M6	M8	M10	M12	M16	-		-	
Internal threaded anchor FIS E	-	-	-	-	-	M6	M8	M10	M12
							11x85		15x85

$N_{Rk} = N_{Rk,p} = N_{Rk,b}$  [kN] depending on the compressive strength  $f_b$  (temperature range 50/80°C)

compressive strength $f_b$	use category	Effective anchorage depth $h_{ef}$ [mm]												
		50	100	50	100	50	100	200	50	100	200	50	100	200
12N/mm <sup>2</sup>	w/w   w/d	1,5	2,0	2,0	2,0	2,5	- <sup>1)</sup>	2,0	2,5	- <sup>1)</sup>	2,0	5,5	- <sup>1)</sup>	- <sup>1)</sup>
	d/d	2,5	3,0	4,0	3,0	4,0	9,5	3,0	4,0	9,5	3,0	8,5	9,5	- <sup>1)</sup>
20N/mm <sup>2</sup>	w/w   w/d	2,0	2,5	3,0	2,5	3,5	- <sup>1)</sup>	3,0	3,5	- <sup>1)</sup>	3,0	7,5	- <sup>1)</sup>	- <sup>1)</sup>
	d/d	3,5	4,5	5,5	4,5	5,5	12	4,5	5,5	12	4,5	12	12	- <sup>1)</sup>
28N/mm <sup>2</sup>	w/w   w/d	2,5	3,0	4,0	3,0	4,0	- <sup>1)</sup>	3,5	4,0	- <sup>1)</sup>	3,5	9,0	- <sup>1)</sup>	- <sup>1)</sup>
	d/d	4,0	5,5	6,5	5,5	6,5	12	5,5	6,5	12	5,5	12	12	- <sup>1)</sup>

<sup>1)</sup> No performance assessed

Factor for temperature range 72/120°C: 0,83

**Table C7.2:** Characteristic resistance under shear load for edge distance  $c=60\text{mm}$

Anchor rod	M6	M8	M10	M12	M16	-		-	
Internal threaded anchor FIS E	-	-	-	-	-	M6	M8	M10	M12
							11x85		15x85

$V_{Rk} = V_{Rk,b} = V_{Rk,c}$  [kN] depending on the compressive strength  $f_b$  (temperature range 50/80°C and 72/120°C)

compressive strength $f_b$	use category	Effective anchorage depth $h_{ef}$ [mm]													
		50	100	50	100	50	100	200	50	100	200	50	100	200	85
12N/mm <sup>2</sup>	w/w   w/d	1,2	2,5	1,2	3,0	2,0	3,0	1,5	1,5	3,0	3,0	0,6	3,0	4,5	- <sup>1)</sup>
	d/d														
20N/mm <sup>2</sup>	w/w   w/d	1,5	3,5	1,5	4,5	3,0	4,5	2,5	2,0	4,5	4,5	0,9	4,5	6,0	- <sup>1)</sup>
	d/d														
28N/mm <sup>2</sup>	w/w   w/d	2,0	4,0	2,0	5,0	3,5	5,0	3,0	2,5	5,0	5,0	1,2	5,0	7,5	- <sup>1)</sup>
	d/d														

<sup>1)</sup> No performance assessed

Factor for job site tests and displacements see annex C110

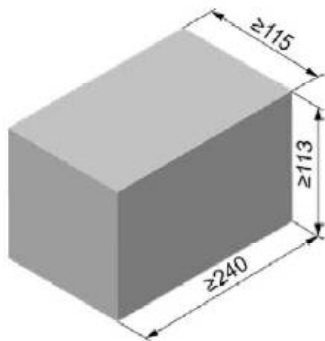
fischer injection system FIS V Plus for masonry

**Performance**  
Solid brick Mz, NF, Characteristic resistance under tension and shear load  $c=60\text{mm}$

**Annex C 7**



**Solid brick Mz, 2DF, EN 771-1:2015**



Solid brick Mz, 2DF, EN 771-1:2015			
Producer	e.g. Wienerberger		
Nominal dimensions [mm]	length L	width W	height H
	≥ 240	≥ 115	≥ 113
Density $\rho$ [kg/dm <sup>3</sup> ]	≥ 1,8		
Compressive strength $f_b$ [N/mm <sup>2</sup> ]	10 / 16		
Standard or annex	EN 771-1:2015		

**Table C8.1:** Installation parameters

Anchor rod		M6	M8	M10	M12	M16	-	-
Internal threaded anchor FIS E		-	-	-	-	-	M6 11x85	M8 15x85
Anchor rod and internal threaded anchor FIS E without perforated sleeve								
Effective anchorage depth $h_{ef}$ [mm]		50	100	50	100	50	100	50
Max. installation torque $T_{inst}$ [Nm]		4	10				4	10
Anchor rod and internal threaded anchor FIS E with perforated sleeve FIS H 16x85 K								
Effective anchorage depth $h_{ef}$ [mm]		- <sup>1)</sup>		85		- <sup>1)</sup>		85
Max. installation torque $T_{inst}$ [Nm]		- <sup>1)</sup>		10		- <sup>1)</sup>		4 10
General installation parameters								
Edge distance $c_{min}$		60						
Spacing	$s_{min II}$	120						
	$s_{scr II}$	240						
	$s_{scr \perp} = s_{min \perp}$	115						
Drilling method								
Hammer drilling with hard metal hammer drill								
<sup>1)</sup> No performance assessed								
<b>Table C8.2:</b> Group factors								
Anchor rods		M6	M8	M10	M12	M16	-	-
Internal threaded anchor FIS E		-	-	-	-	-	M6 11x85	M8 15x85
Group factor	$\alpha_{g,N II}$	1,5						
	$\alpha_{g,V II}$	1,4						
	$\alpha_{g,N \perp}$	2						
	$\alpha_{g,V \perp}$	-						
fischer injection system FIS V Plus for masonry							<b>Annex C 8</b>	
Performance		Solid brick Mz, 2DF, dimensions, installation parameters						

**Solid brick Mz, 2DF, EN 771-1:2015**

**Table C9.1:** Characteristic resistance under tension load

Anchor rod		M6	M8	M10	M12	M16	-		-		M8	M10	-		
Internal threaded anchor FIS E		-	-	-	-	-	M6	M8	M10	M12	-	-	M6	M8	
							11x85		15x85				11x85		
Perforated sleeve FIS H K		-	-	-	-	-	-	-	16x85						
<b><math>N_{Rk} = N_{Rk,p} = N_{Rk,b}</math> [kN] depending on the compressive strength <math>f_b</math> (temperature range 50/80°C)</b>															
compressive strength $f_b$	use category	Effective anchorage depth $h_{ef}$ [mm]													
		50	100	50	100	50	100	50	100	50	100	85			
10N/mm <sup>2</sup>	w/w	1,5	2,5	1,5	2,5	1,5	3	2	3,5	2	3,5	2		1,5	
	d/d	3	4,0	3,0	4,0	3,0	4,5	3	5,5	3	5,5	3		3	
16N/mm <sup>2</sup>	w/w	2,5	4	2,5	4	2,5	4,5	3,5	5,5	3,5	5,5	3,5		2,5	
	d/d	4,5	7,0	4,5	7,0	4,5	7,5	5,5	8	5,5	8	5,5		4,5	

Factor for temperature range 72/120°C: 0,83

**Table C9.2:** Characteristic resistance under shear load

Anchor rod		M6	M8	M10	M12	M16	-		-		M8	M10	-	
Internal threaded anchor FIS E		-	-	-	-	-	M6	M8	M10	M12	-	-	M6	M8
							11x85		15x85				11x85	
Perforated sleeve FIS H K		-	-	-	-	-	-	-	16x85					
<b><math>V_{Rk} = V_{Rk,b} = V_{Rk,c}</math> [kN] depending on the compressive strength <math>f_b</math> (temperature range 50/80°C and 72/120°C)</b>														
compressive strength $f_b$	use category	Effective anchorage depth $h_{ef}$ [mm]												
		≥ 50						85						
10N/mm <sup>2</sup>	w/w	2,5	3,0	3,0	3,5	3,0	2,5	3,0	3,0	3,0	3,0	3,5	2,5	3,0
	d/d													
16N/mm <sup>2</sup>	w/w	4,0	5,0	5,5	5,5	5,0	4,0	5,0	5,0	5,0	5,0	6,0	4,0	5,0
	d/d													

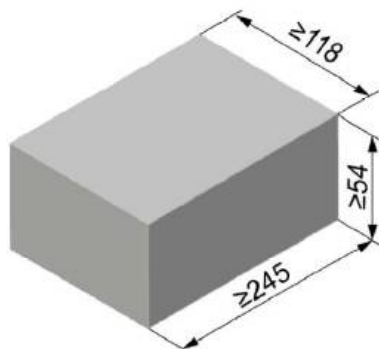
Factor for job site tests and displacements see annex C110

fischer injection system FIS V Plus for masonry

**Performance**  
Solid brick Mz, 2DF, Characteristic resistance under tension and shear load

**Annex C 9**

### Solid brick Mz, EN 771-1:2015



Solid brick Mz, EN 771-1:2015			
Producer	e.g. Nigra		
Nominal dimensions [mm]	length L	width W	height H
	≥ 245	≥ 118	≥ 54
Density $\rho$ [kg/dm <sup>3</sup> ]	≥ 1,8		
Compressive strength $f_b$ [N/mm <sup>2</sup> ]	10 / 20		
Standard or annex	EN 771-1:2015		

**Table C10.1:** Installation parameters

Anchor rod	M6	M8	M10	M12	M16	-	-				
Internal threaded anchor FIS E	-	-	-	-	-	M6	M8	M10	M12		
	11x85		15x85								
Anchor rod and internal threaded anchor FIS E without perforated sleeve											
Effective anchorage depth $h_{ef}$ [mm]	50	100	50	100	50	100	50	100	50	100	85
Max. installation torque $T_{inst}$ [Nm]	4		10				4		10		
General installation parameters											
Edge distance $c_{min}$						60					
Spacing	$s_{cr \parallel} = s_{min \parallel}$ [mm]					245					
	$s_{cr \perp} = s_{min \perp}$					60					
Drilling method											
Hammer drilling with hard metal hammer drill											

**Table C10.2:** Group factors

Anchor rods	M6	M8	M10	M12	M16	-	-		
Internal threaded anchor FIS E	-	-	-	-	-	M6	M8	M10	M12
	11x85		15x85						
Group factor	$\alpha_{g,N \parallel}$	[-]							
	$\alpha_{g,V \parallel}$		2						
	$\alpha_{g,N \perp}$								
	$\alpha_{g,V \perp}$								

fischer injection system FIS V Plus for masonry

**Performance**  
Solid brick Mz, dimensions, installation parameters

**Annex C 10**

**Solid brick Mz, EN 771-1:2015**

**Table C11.1:** Characteristic resistance under tension load

Anchor rod		M6	M8	M10	M12	M16	-		-		
Internal threaded anchor FIS E		-	-	-	-	-	M6	M8	M10	M12	
				11x85		15x85					
<b><math>N_{Rk} = N_{Rk,p} = N_{Rk,b}</math> [kN] depending on the compressive strength <math>f_b</math> (temperature range 50/80°C)</b>											
compressive strength $f_b$	use category	Effective anchorage depth $h_{ef}$ [mm]									
		≥ 50						85			
10N/mm <sup>2</sup>	w/w	w/d	0,6	0,9	0,75	0,75	0,75	0,6	0,75		
	d/d		1,2	1,5	1,2	1,2	1,2	1,2	1,2	1,2	
20N/mm <sup>2</sup>	w/w	w/d	0,9	1,5	1,2	1,2	1,2	0,9	1,2		
	d/d		1,5	2,5	2,0	2,0	2,0	1,5	2,0		

Factor for temperature range 72/120°C: 0,83

**Table C11.2:** Characteristic resistance under shear load

Anchor rod		M6	M8	M10	M12	M16	-		-		
Internal threaded anchor FIS E		-	-	-	-	-	M6	M8	M10	M12	
				11x85		15x85					
<b><math>V_{Rk} = V_{Rk,b} = V_{Rk,c}</math> [kN] depending on the compressive strength <math>f_b</math> (temperature range 50/80°C and 72/120°C)</b>											
compressive strength $f_b$	use category	Effective anchorage depth $h_{ef}$ [mm]									
		≥ 50						85			
10N/mm <sup>2</sup>	w/w	w/d	2,0	3,0	4,0	4,5	5,5	2,0	3,0	4,0	4,5
	d/d										
20N/mm <sup>2</sup>	w/w	w/d	2,5	4,0	5,5	6,0	8,0	2,5	4,0	5,5	6,0
	d/d										

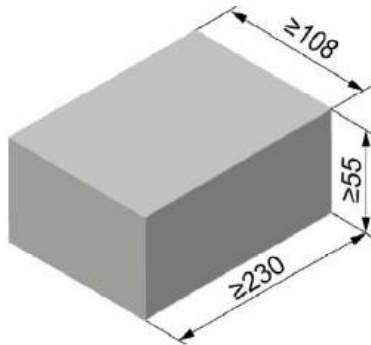
Factor for job site tests and displacements see annex C110

fischer injection system FIS V Plus for masonry

**Performance**  
Solid brick Mz, Characteristic resistance under tension and shear load

**Annex C 11**

**Solid brick Mz, EN 771-1:2015**



Solid brick Mz, EN 771-1:2015			
Producer	e.g. Wienerberger		
Nominal dimensions [mm]	length L	width W	height H
	≥ 230	≥ 108	≥ 55
Density $\rho$ [kg/dm <sup>3</sup> ]	≥ 1,8		
Compressive strength $f_b$ [N/mm <sup>2</sup> ]	10 / 20		
Standard or annex	EN 771-1:2015		

**Table C12.1:** Installation parameters

Anchor rod	M6	M8	M10	M12	M16	-	-			
Internal threaded anchor FIS E	-	-	-	-	-	M6	M8	M10	M12	
	11x85		15x85							
Anchor rod and internal threaded anchor FIS E without perforated sleeve										
Effective anchorage depth $h_{ef}$ [mm]	50	90	50	90	50	90	50	90	85	
Max. installation torque $T_{inst}$ [Nm]	4		10				4	10		
General installation parameters										
Edge distance $c_{min}$	60									
Spacing	$S_{cr \parallel} = S_{min \parallel}$ [mm]									
	230									
	$S_{cr \perp} = S_{min \perp}$									
									60	
Drilling method										
Hammer drilling with hard metal hammer drill										

**Table C12.2:** Group factors

Anchor rods	M6	M8	M10	M12	M16	-	-		
Internal threaded anchor FIS E	-	-	-	-	-	M6	M8	M10	M12
	11x85		15x85						
Group factor	$\alpha_{g,N \parallel}$	[-]							
	$\alpha_{g,V \parallel}$		2						
	$\alpha_{g,N \perp}$								
	$\alpha_{g,V \perp}$								

fischer injection system FIS V Plus for masonry

**Performance**  
Solid brick Mz, dimensions, installation parameters

**Annex C 12**



### Solid brick Mz, EN 771-1:2015

**Table C13.1:** Characteristic resistance under tension load

Anchor rod		M6	M8	M10	M12	M16	-		-		
Internal threaded anchor FIS E		-	-	-	-	-	M6	M8	M10	M12	
								11x85		15x85	
<b><math>N_{Rk} = N_{Rk,p} = N_{Rk,b}</math> [kN] depending on the compressive strength <math>f_b</math> (temperature range 50/80°C)</b>											
compressive strength $f_b$	use category	Effective anchorage depth $h_{ef}$ [mm]									
		≥ 50							85		
10N/mm <sup>2</sup>	w/w	w/d	0,6	0,9	0,75	0,75	0,75	0,75			
	d/d		1,2	1,5	1,2	1,2	1,2	1,2			
20N/mm <sup>2</sup>	w/w	w/d	0,9	1,5	1,2	1,2	1,2	1,2			
	d/d		1,5	2,5	2,0	2,0	2,0	2,0			

Factor for temperature range 72/120°C: 0,83

**Table C13.2:** Characteristic resistance under shear load

Anchor rod		M6	M8	M10	M12	M16	-		-		
Internal threaded anchor FIS E		-	-	-	-	-	M6	M8	M10	M12	
								11x85		15x85	
<b><math>V_{Rk} = V_{Rk,b} = V_{Rk,c}</math> [kN] depending on the compressive strength <math>f_b</math> (temperature range 50/80°C and 72/120°C)</b>											
compressive strength $f_b$	use category	Effective anchorage depth $h_{ef}$ [mm]									
		≥ 50							85		
10N/mm <sup>2</sup>	w/w	w/d	2,0	3,0	4,0	4,5	5,5	2,0	3,0	4,0	4,5
	d/d										
20N/mm <sup>2</sup>	w/w	w/d	2,5	4,0	5,5	6,0	8,0	2,5	4,0	5,5	6,0
	d/d										

Factor for job site tests and displacements see annex C110

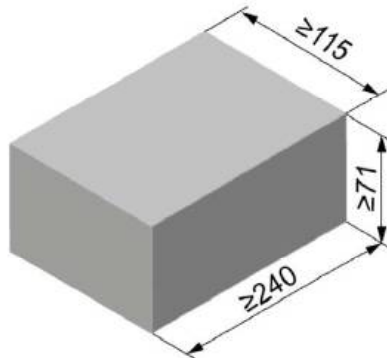
fischer injection system FIS V Plus for masonry

**Performance**

Solid brick Mz, Characteristic resistance under tension and shear load

**Annex C 13**

**Solid sand-lime brick KS, NF, EN 771-2:2015**



Solid sand-lime brick KS, NF, EN 771-2:2015			
Producer			
Nominal dimensions [mm]	length L	width W	height H
	≥ 240	≥ 115	≥ 71
Density $\rho$ [kg/dm <sup>3</sup> ]	≥ 1,8		
Compressive strength $f_b$ [N/mm <sup>2</sup> ]	12 / 20 / 28		
Standard or annex	EN 771-2:2015		

**Table C14.1:** Installation parameters

Anchor rod	M6	M8	M10	M12	M16	-		-			
Internal threaded anchor FIS E	-	-	-	-	-	M6	M8	M10	M12		
	11x85		15x85								
<b>Anchor rod and internal threaded anchor FIS E without perforated sleeve</b>											
Effective anchorage depth $h_{ef}$ [mm]	50	100	50	100	50	100	50	100	85	85	
	200		200		200						
Max. installation torque $T_{inst}$ [Nm]	3	5	15	15	25	3	5	15			
<b>General installation parameters</b>											
Edge distance $c_{min}$					60						
Spacing	$s_{min} \parallel$					80					
	$s_{cr} \parallel$ [mm]					80					
	$s_{min} \perp$					3x $h_{ef}$					
	$s_{cr} \perp$					3x $h_{ef}$					
	<b>Drilling method</b>										
Hammer drilling with hard metal hammer drill											

**Table C14.2:** Group factors

Anchor rod	M6	M8	M10	M12	M16	-		-			
Internal threaded anchor FIS E	-	-	-	-	-	M6	M8	M10	M12		
	11x85		15x85								
Group factor	$\alpha_{g,N} \parallel$					0,7					
	$\alpha_{g,V} \parallel$					1,3					
	$\alpha_{g,N} \perp$					2,0					
	$\alpha_{g,V} \perp$					2,0					

fischer injection system FIS V Plus for masonry

**Performance**  
Solid sand-lime brick KS, NF, dimensions, installation parameters

**Annex C 14**

### Solid sand-lime brick KS, NF, EN 771-2:2015

**Table C15.1:** Characteristic resistance under tension load

Anchor rod		M6		M8		M10		M12		M16		-		-			
Internal threaded anchor FIS E		-		-		-		-		-		M6	M8	M10	M12		
												11x85		15x85			
<b><math>N_{Rk} = N_{Rk,p} = N_{Rk,b}</math> [kN] depending on the compressive strength <math>f_b</math> (temperature range 50/80°C)</b>																	
compressive strength $f_b$	use category		Effective anchorage depth $h_{ef}$ [mm]												85	85	
	50	100	50	100	50	100	200	50	100	200	50	100	200	85			85
12N/mm <sup>2</sup>	w/w	w/d	2,0	3,0	2,5	4,5	2,5	3,5	7,0	2,5	3,0	6,5	2,5	3,5	8,0	2,5	2,5
	d/d		4,0	5,5	4,0	8,0	4,0	5,5	12	4,0	4,5	12	4,5	5,5	12	4,0	4,0
20N/mm <sup>2</sup>	w/w	w/d	3,0	4,5	3,5	6,5	3,5	4,5	10	3,5	4,0	9,5	4,0	5,0	11	3,5	3,5
	d/d		5,5	7,5	6,0	11	6,0	8,0	12	6,0	6,5	12	6,5	8,0	12	6,0	6,0
28N/mm <sup>2</sup>	w/w	w/d	3,5	5,0	4,0	8,0	4,5	5,5	12	4,5	5,0	11	4,5	5,5	12	4,5	4,5
	d/d		6,5	9,0	7,0	12	7,0	9,0	12	7,0	7,5	12	7,5	9,5	12	7,0	7,0

Factor for temperature range 72/120°C: 0,83

**Table C15.2:** Characteristic resistance under shear load

Anchor rod		M6		M8		M10		M12		M16		-		-		
Internal threaded anchor FIS E		-		-		-		-		-		M6	M8	M10	M12	
												11x85		15x85		
<b><math>V_{Rk} = V_{Rk,b} = V_{Rk,c}</math> [kN] depending on the compressive strength <math>f_b</math> (temperature range 50/80°C and 72/120°C)</b>																
compressive strength $f_b$	use category		Effective anchorage depth $h_{ef}$ [mm]										85	85		
	50	100	50	100	50	≥100	50	≥100	50	≥100	50	≥100			85	85
12N/mm <sup>2</sup>	w/w	w/d	1,5	3,0	1,5	3,0	1,2	2,0	1,2	2,0	1,2	2,0	1,2	2,0	1,2	1,2
	d/d															
20N/mm <sup>2</sup>	w/w	w/d	2,5	4,0	2,5	4,0	1,5	3,0	1,5	3,0	1,5	3,0	1,5	3,0	1,5	1,5
	d/d															
28N/mm <sup>2</sup>	w/w	w/d	3,0	4,5	3,0	4,5	1,5	3,5	1,5	3,5	1,5	3,5	1,5	3,5	1,5	1,5
	d/d															

Factor for job site tests and displacements see annex C110

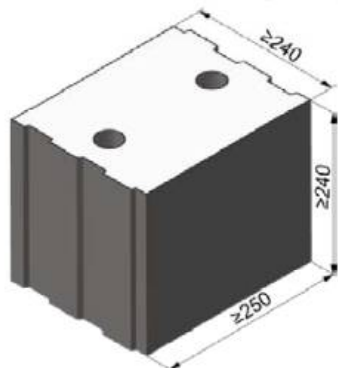
fischer injection system FIS V Plus for masonry

**Performance**

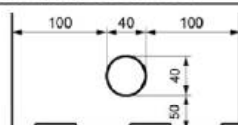
Solid sand-lime brick KS, NF, Characteristic resistance under tension and shear load

**Annex C 15**

**Solid sand-lime brick KS, 8DF, EN 771-2:2015**



Solid sand-lime brick KS, 8DF, EN 771-2:2015			
Producer	-		
Nominal dimensions [mm]	length L	width W	height H
	≥ 250	≥ 240	≥ 240
Density $\rho$ [kg/dm <sup>3</sup> ]	≥ 2,0		
Compressive strength $f_b$ [N/mm <sup>2</sup> ]	10 / 20 / 28		
Standard or annex	EN 771-2:2015		



Dimension see also Annex B 15

**Table C16.1:** Installation parameters

Anchor rod		M6	M8	M10	M12	M16	-	-		
Internal threaded anchor FIS E		-	-	-	-	-	M6	M8		
							11x85	15x85		
<b>Anchor rod and internal threaded anchor FIS E without perforated sleeve</b>										
Effective anchorage depth $h_{ef}$ [mm]		50	100	50	100	50	100	50	100	85
Max. installation torque $T_{inst}$ [Nm]		4	10				4	10		
<b>Anchor rod and internal threaded anchor FIS E with perforated sleeve FIS H 16x85 K</b>										
Effective anchorage depth $h_{ef}$ [mm]		- <sup>1)</sup>	85			- <sup>1)</sup>	85		- <sup>1)</sup>	
Max. installation torque $T_{inst}$ [Nm]			10				4	10		
<b>General installation parameters</b>										
Edge distance $c_{min}$						60				
Spacing	$s_{min \parallel}$					80				
	$s_{cr \parallel}$					3x $h_{ef}$				
	$s_{min \perp}$					80				
	$s_{cr \perp}$					3x $h_{ef}$				
<b>Drilling method</b>										
Hammer drilling with hard metal hammer drill										
<sup>1)</sup> No performance assessed										
<b>Table C16.2:</b> Group factors										
Anchor rods		M6	M8	M10	M12	M16	-	-		
Internal threaded anchor FIS E		-	-	-	-	-	M6	M8		
							11x85	15x85		
Group factors	$\alpha_{g,N \parallel}$					1,5				
	$\alpha_{g,V \parallel}$					1,2				
	$\alpha_{g,N \perp}$					1,5				
	$\alpha_{g,V \perp}$					1,2				
fischer injection system FIS V Plus for masonry							<b>Annex C 16</b>			
Performance Solid sand-lime brick KS, 8DF, dimensions, installation parameters										

### Solid sand-lime brick KS, 8DF, EN 771-2:2015

**Table C17.1:** Characteristic resistance under tension load

Anchor rod	M6	M8	M10	M12	M16	-	-	M8	M10	-			
Internal threaded anchor FIS E	-	-	-	-	-	M6	M8	M10	M12	-	-	M6	M8
						11x85		15x85				11x85	
Perforated sleeve FIS H K	-	-	-	-	-	-	-	16x85					
<b><math>N_{Rk} = N_{Rk,p} = N_{Rk,b}</math> [kN] depending on the compressive strength <math>f_b</math> (temperature range 50/80°C)</b>													
compressive strength $f_b$	use category		Effective anchorage depth $h_{ef}$ [mm]										
			≥ 50					85					
10N/mm <sup>2</sup>	w/w	w/d	3,0	4,0	4,5	4,5	3,5	3,0	3,5	4,5	3,0	4,5	
	d/d		5,0	7,0	7,0	7,0	5,5	5,0	5,5	8,0	5,0	8,0	
20N/mm <sup>2</sup>	w/w	w/d	4,5	6,0	6,0	6,0	5,0	4,5	5,0	6,5	4,5	6,5	
	d/d		7,5	10,0	10,0	10,0	7,5	7,5	7,5	11,0	7,5	11	
28N/mm <sup>2</sup>	w/w	w/d	5,0	8,0	8,5	8,5	7,0	5,0	7,0	8,5	5,0	8,5	
	d/d		8,5	12,0	12,0	12,0	11,0	8,5	11,0	12,0	8,5	12	

Factor for temperature range 72/120°C: 0,83

**Table C17.2:** Characteristic resistance under shear load

Anchor rod	M6	M8	M10	M12	M16	-	-	M8	M10	-					
Internal threaded anchor FIS E	-	-	-	-	-	M6	M8	M10	M12	-	-	M6	M8		
						11x85		15x85				11x85			
Perforated sleeve FIS H K	-	-	-	-	-	-	-	16x85							
<b><math>V_{Rk} = V_{Rk,b} = V_{Rk,c}</math> [kN] depending on the compressive strength <math>f_b</math> (temperature range 50/80°C and 72/120°C)</b>															
compressive strength $f_b$	use category		Effective anchorage depth $h_{ef}$ [mm]												
			≥ 50					85							
10N/mm <sup>2</sup>	w/w	w/d	2,5	4,5					2,5	4,5			2,5	4,5	
	d/d			4,5			4,5								
20N/mm <sup>2</sup>	w/w	w/d	4,0	6,5					4,0	6,5			4,0	6,5	
	d/d			6,5			6,5								
28N/mm <sup>2</sup>	w/w	w/d	5,0	9,0					5,0	9,0			5,0	9,0	
	d/d			9,0			9,0								

Factor for job site tests and displacements see annex C110

fischer injection system FIS V Plus for masonry

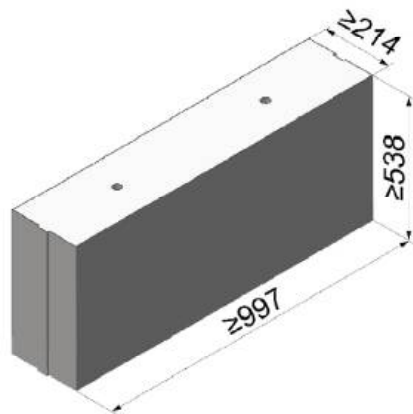
**Performance**

Solid sand-lime brick KS, 8DF, Characteristic resistance under tension and shear load

**Annex C 17**



### Solid sand-lime brick KS, EN 771-2:2015



Solid sand-lime brick KS, EN 771-2:2015			
Producer	e.g. Calduran		
Nominal dimensions [mm]	length L	width W	height H
	≥ 997	≥ 214	≥ 538
Density $\rho$ [kg/dm <sup>3</sup> ]	1,8		2,2
Compressive strength $f_b$ [N/mm <sup>2</sup> ]	10 / 20		36
Standard or annex	EN 771-2:2015		



**Table C18.1:** Installation parameters

Anchor rod	M6	M8	M10	M12	M16	-	-			
Internal threaded anchor FIS E	-	-	-	-	-	M6	M8	M10	M12	
							11x85	15x85		
<b>Anchor rod and internal threaded anchor FIS E without perforated sleeve</b>										
Effective anchorage depth $h_{ef}$ [mm]	50	100	50	100	50	100	50	100	85	
Max. installation torque $T_{inst}$ [Nm]	4		10				4	10		
<b>General installation parameters</b>										
Edge distance $c_{min}$					75					
Spacing	$s_{cr \parallel} = s_{min \parallel}$ [mm]						3x $h_{ef}$			
	$s_{cr \perp} = s_{min \perp}$						3x $h_{ef}$			
<b>Drilling method</b>										
Hammer drilling with hard metal hammer drill										

**Table C18.2:** Group factors

Anchor rod	M6	M8	M10	M12	M16	-	-			
Internal threaded anchor FIS E	-	-	-	-	-	M6	M8	M10	M12	
							11x85	15x85		
Group factors	$\alpha_{g,N \parallel}$	[-]					2			
	$\alpha_{g,V \parallel}$									
	$\alpha_{g,N \perp}$									
	$\alpha_{g,V \perp}$									

fischer injection system FIS V Plus for masonry

**Performance**  
Solid sand-lime brick KS, dimensions, installation parameters

**Annex C 18**

### Solid sand-lime brick KS, EN 771-2:2015

**Table C19.1:** Characteristic resistance under tension load

Anchor rod		M6	M8	M10	M12	M16	-		-		
Internal threaded anchor FIS E		-	-	-	-	-	M6	M8	M10	M12	
<b><math>N_{Rk} = N_{Rk,p} = N_{Rk,b}</math> [kN] depending on the compressive strength <math>f_b</math> (temperature range 50/80°C)</b>											
compressive strength $f_b$	use category	Effective anchorage depth $h_{ef}$ [mm]									
		50	100	50	100	50	100	50	100	50	100
10N/mm <sup>2</sup>	w/w	4,0	4,0	7,0	5,0	6,0	5,0	6,0	5,5	7,5	5,5
	d/d	7,0	7,0	12,0	8,0	9,5	8,0	10,0	9,0	11,5	9,0
20N/mm <sup>2</sup>	w/w	5,5	6,0	10,0	7,0	8,5	7,0	9,0	8,0	11,0	8,0
	d/d	8,5	10,5	12,0	11,5	12,0	11,0	12,0	12,0	12,0	12,0
36N/mm <sup>2</sup>	w/w	4,5	8,0	12,0	11,5	12,0	12,0	12,0	12,0	12,0	12,0
	d/d	8,0	12,0	12,0	12,0	12,0	12,0	12,0	12,0	12,0	12,0

Factor for temperature range 72/120°C: 0,83

**Table C19.2:** Characteristic resistance under shear load

Anchor rod		M6	M8	M10	M12	M16	-		-		
Internal threaded anchor FIS E		-	-	-	-	-	M6	M8	M10	M12	
<b><math>V_{Rk} = V_{Rk,b} = V_{Rk,c}</math> [kN] depending on the compressive strength <math>f_b</math> (temperature range 50/80°C and 72/120°C)</b>											
compressive strength $f_b$	use category	Effective anchorage depth $h_{ef}$ [mm]									
		≥ 50								85	
10N/mm <sup>2</sup>	w/w	3,0	5,0	5,5	4,0	4,0	3,0	5,0	5,5	4,0	
	d/d										
20N/mm <sup>2</sup>	w/w	4,5	7,0	7,5	6,0	6,0	4,5	7,0	7,5	6,0	
	d/d										
36N/mm <sup>2</sup>	w/w	4,5	9,0	11,0	12,0	12,0	4,5	9,0	11,0	12,0	
	d/d										

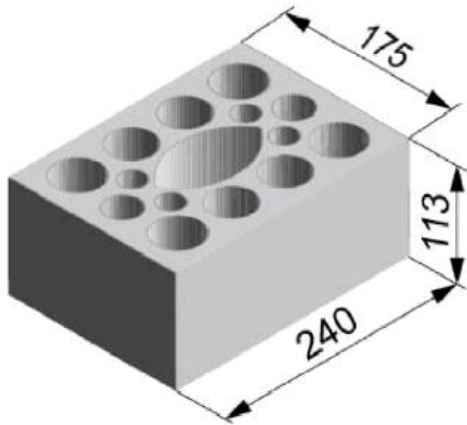
Factor for job site tests and displacements see annex C110

fischer injection system FIS V Plus for masonry

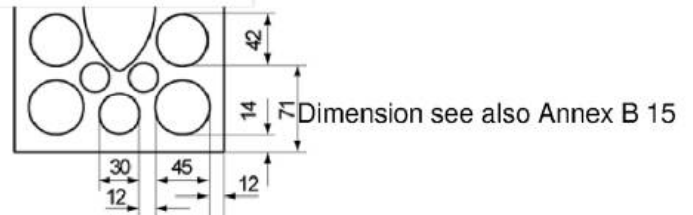
**Performance**  
Solid sand-lime brick KS, Characteristic resistance under tension and shear load

**Annex C 19**

**Perforated sand-lime brick KSL, 3DF, EN 771-2:2015**



Perforated sand-lime brick KSL, 3DF, EN 771-2:2015			
Producer	e.g. KS Wemding		
Nominal dimensions [mm]	length L	width W	height H
	240	175	113
Density $\rho$ [kg/dm <sup>3</sup> ]	≥ 1,4		
Compressive strength $f_b$ [N/mm <sup>2</sup> ]	8 / 10 / 12 / 16 / 20		
Standard or annex	EN 771-2:2015		



**Tabelle C20.1:** Installation parameters  
(Pre-positioned anchorage with perforated sleeve FIS H K)

Anchor rod	M6	M8	M6	M8	-	M8	M10	M8	M10	-	M12	M16	M12	M16
Internal threaded anchor FIS E	-	-	-	-	M6	M8	-	-	-	M10	M12	-	-	-
					11x85					15x85				
Perforated sleeve FIS H K	12x50		12x85		16x85			16x130		20x85			20x130	
Anchor rod and internal threaded anchor FIS E with perforated sleeve FIS H K														
Max. installation torque	$T_{inst}$	[Nm]	2											
General installation parameters														
Edge distance	$C_{min}$		60				80							
Spacing	$S_{min \parallel}$	[mm]					100							
	$S_{scr \parallel}$						240							
	$S_{min \perp}$						115							
	$S_{scr \perp}$						115							
Drilling method														
Hammer drilling with hard metal hammer drill														

**Table C20.2:** Group factors

Anchor rod	M6	M8	M6	M8	-	M8	M10	M8	M10	-	M12	M16	M12	M16
Internal threaded anchor FIS E	-	-	-	-	M6	M8	-	-	-	M10	M12	-	-	-
					11x85					15x85				
Perforated sleeve FIS H K	12x50		12x85		16x85			16x130		20x85			20x130	
Group factors	$\alpha_{g,N \parallel} = \alpha_{g,V \parallel}$	[-]	1,5											
	$\alpha_{g,N \perp} = \alpha_{g,V \perp}$		2,0											

fischer injection system FIS V Plus for masonry

**Performance**  
Perforated sand-lime brick KSL, 3DF, dimensions, installation parameters

**Annex C 20**

**Perforated sand-lime brick KSL, 3DF, EN 771-2:2015**

**Table C21.1:** Installation parameters  
(Push through anchorage with perforated sleeve FIS H K)

Anchor rod		M10	M12	M16
Perforated sleeve FIS H K		18x130/200		22x130/200
Anchor rod with perforated sleeve FIS H K				
Max. installation torque	$T_{inst}$ [Nm]	2		
<b>General installation parameters</b>				
Edge distance	$c_{min}$	80		
Spacing	$s_{min \parallel}$	100		
	$s_{cr \parallel}$ [mm]	240		
	$s_{min \perp}$	115		
	$s_{cr \perp}$	115		
<b>Drilling method</b>				
Hammer drilling with hard metal hammer drill				

**Table C21.2:** Group factors

Anchor rod		M10	M12	M16
Perforated sleeve FIS H K		18x130/200		22x130/200
Group factors	$\alpha_{g,N \parallel}$	[-]	1,5	
	$\alpha_{g,V \parallel}$			
	$\alpha_{g,N \perp}$		2,0	
	$\alpha_{g,V \perp}$			

fischer injection system FIS V Plus for masonry

**Performance**  
Perforated sand-lime brick KSL, 3DF, dimensions, installation parameters

**Annex C 21**

**Perforated sand-lime brick KSL, 3DF, EN 771-2:2015**

**Table C22.1:** Characteristic resistance under tension load (Pre-positioned anchorage)

Anchor rod	M6	M8	M6	M8	-	M8	M10	M8	M10	-	M12	M16	M12	M16
Internal threaded anchor FIS E	-		-		M6	M8	-		-		M10	M12	-	
					11x85						15x85			
Perforated sleeve FIS H K	12x50		12x85		16x85			16x130		20x85			20x130	
<b><math>N_{Rk} = N_{Rk,p} = N_{Rk,b}</math> [kN] depending on the compressive strength <math>f_b</math> (temperature range 50/80°C)</b>														
compressive strength $f_b$	use category													
	w/w	w/d												
8 N/mm <sup>2</sup>	d/d		1,5		2,0		2,0		2,0		2,0		2,0	
			1,5		2,0		2,5		2,5		2,5		2,5	
10 N/mm <sup>2</sup>	w/w		2,0		2,0		2,5		2,5		2,5		2,5	
	d/d		2,0		2,5		3,0		3,0		3,0		3,0	
12 N/mm <sup>2</sup>	w/w		2,5		2,5		3,0		3,0		3,0		3,0	
	d/d		2,5		3,0		3,5		3,5		3,5		3,5	
16 N/mm <sup>2</sup>	w/w		3,0		3,5		4,5		4,5		4,5		4,5	
	d/d		3,5		4,0		4,5		4,5		4,5		4,5	
20 N/mm <sup>2</sup>	w/w		4,0		4,5		5,5		5,5		5,5		5,5	
	d/d		4,5		5,0		6,0		6,0		6,0		6,0	

**Table C22.2:** Characteristic resistance under tension load (Push through anchorage)

Anchor rod	M10	M12	M16
Perforated sleeve FIS H K	18x130/200		22x130/200
<b><math>N_{Rk} = N_{Rk,p} = N_{Rk,b}</math> [kN] depending on the compressive strength <math>f_b</math> (temperature range 50/80°C)</b>			
compressive strength $f_b$	use category		
	w/w	w/d	
8 N/mm <sup>2</sup>	d/d		2,0
			2,5
10 N/mm <sup>2</sup>	w/w		2,5
	d/d		3,0
12 N/mm <sup>2</sup>	w/w		3,0
	d/d		3,5
16 N/mm <sup>2</sup>	w/w		4,5
	d/d		4,5
20 N/mm <sup>2</sup>	w/w		5,5
	d/d		6,0

Factor for job site tests and displacements see annex C110

Factor for temperature range 72/120°C: 0,83

fischer injection system FIS V Plus for masonry

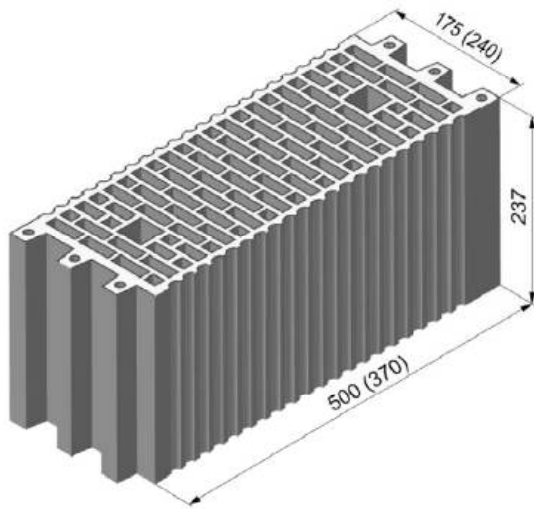
**Performance**  
Perforated sand-lime brick KSL, 3DF, Characteristic resistance under tension load

**Annex C 22**

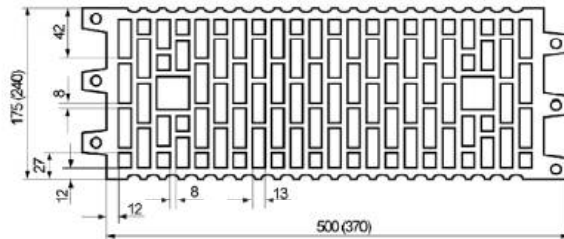


<b>Perforated sand-lime brick KSL, 3DF, EN 771-2:2015</b>																
<b>Table C23.1: Characteristic resistance under shear load (Pre-positioned anchorage)</b>																
Anchor rod	M6	M8	M6	M8	-	M8	M10	M8	M10	-	M12	M16	M12	M16		
Internal threaded anchor FIS E	-		-		M6	M8	-		-		M10	M12	-			
					11x85						15x85					
Perforated sleeve FIS H K	12x50		12x85		16x85			16x130		20x85			20x130			
<b><math>V_{Rk} = V_{Rk,b} = V_{Rk,c}</math> [kN] depending on the compressive strength <math>f_b</math> (temperature range 50/80°C and 72/120°C)</b>																
compressive strength $f_b$	use category															
8 N/mm <sup>2</sup>	w/w	w/d	1,5					3,0					2,5	3,0	2,5	
	d/d															
10 N/mm <sup>2</sup>	w/w	w/d	2,0					3,5								
	d/d															
12 N/mm <sup>2</sup>	w/w	w/d	2,5					4,5					4,0	4,5	4,0	
	d/d															
16 N/mm <sup>2</sup>	w/w	w/d	3,0	3,5	3,0	3,5	3,0	6,0					5,5	6,0	5,5	
	d/d															
20 N/mm <sup>2</sup>	w/w	w/d	4,0	4,5	4,0	4,5	4,0	7,5					6,5	7,5	6,5	
	d/d															
<b>Table C23.2: Characteristic resistance under shear load (Push through anchorage)</b>																
Anchor rod	M10					M12					M16					
Perforated sleeve FIS H K	18x130/200										22x130/200					
<b><math>V_{Rk} = V_{Rk,b} = V_{Rk,c}</math> [kN] depending on the compressive strength <math>f_b</math> (temperature range 50/80°C and 72/120°C)</b>																
compressive strength $f_b$	use category															
8 N/mm <sup>2</sup>	w/w	w/d	3,0					2,5								
	d/d															
10 N/mm <sup>2</sup>	w/w	w/d	3,5					3,5								
	d/d															
12 N/mm <sup>2</sup>	w/w	w/d	4,5					4,0								
	d/d															
16 N/mm <sup>2</sup>	w/w	w/d	6,0					5,5								
	d/d															
20 N/mm <sup>2</sup>	w/w	w/d	7,5					6,5								
	d/d															
Factor for job site tests and displacements see annex C110																
fischer injection system FIS V Plus for masonry												<b>Annex C 23</b>				
Performance Perforated sand-lime brick KSL, 3DF, Characteristic resistance under shear load																

**Vertical perforated brick HLz, EN 771-1:2015**



Vertical perforated brick HLz, EN 771-1:2015			
Producer	e.g. Wienerberger, Poroton		
Nominal dimensions [mm]	length L	width W	height H
	500	175	237
	370	240	237
Density $\rho$ [kg/dm <sup>3</sup> ]	≥ 1,0		
Compressive strength $f_b$ [N/mm <sup>2</sup> ]	4 / 6 / 8 / 10 / 12		
Standard or annex	EN 771-1:2015		



Dimension see also Annex B 15

**Table C24.1:** Installation parameters

Anchor rod		M6	M8	M6	M8	-	M8	M10	M8	M10	-	M12	M16	M12	M16
Internal threaded anchor FIS E		-	-			M6	M8				M10	M12			
						11x85					15x85				
Perforated sleeve FIS H K		12x50	12x85	16x85		16x130		20x85		20x130					
Anchor rod and internal threaded anchor FIS E with perforated sleeve FIS H K															
Max. installation torque	$T_{inst}$ [Nm]	2													
General installation parameters															
Edge distance	$c_{min}$	100													
	$s_{min \parallel}$	100													
	$s_{scr \parallel}$ [mm]	500 (370)													
	$s_{min \perp}$	100													
	$s_{scr \perp}$	240													
Drilling method															
Hammer drilling with hard metal hammer drill															

**Table C24.2:** Group factors

Anchor rod		M6	M8	M6	M8	-	M8	M10	M8	M10	-	M12	M16	M12	M16
Internal threaded anchor FIS E		-	-			M6	M8				M10	M12			
						11x85					15x85				
Perforated sleeve FIS H K		12x50	12x85	16x85		16x130		20x85		20x130					
Group factors	$\frac{\alpha_{g,N \parallel} = \alpha_{g,V \parallel}}{\alpha_{g,N \perp} = \alpha_{g,V \perp}}$ [-]	1													

fischer injection system FIS V Plus for masonry

**Performance**  
Vertical perforated brick HLz, dimensions, installation parameters

**Annex C 24**

### Vertical perforated brick HLz, EN 771-1:2015

**Table C25.1:** Characteristic resistance under tension load

Anchor rod		M6	M8	M6	M8	-	M8	M10	M8	M10	-	M12	M16	M12	M16
Internal threaded anchor FIS E		-		-		M6	M8	-		-		M10	M12	-	
						11x85						15x85			
Perforated sleeve FIS H K		12x50		12x85		16x85			16x130		20x85			20x130	
<b><math>N_{Rk} = N_{Rk,p} = N_{Rk,b}</math> [kN] depending on the compressive strength <math>f_b</math> (temperature range 50/80°C)</b>															
compressive strength $f_b$		use category													
4 N/mm <sup>2</sup>	w/w	w/d	0,3						0,9			1,2			
	d/d		0,4						0,9			1,2			
6 N/mm <sup>2</sup>	w/w	w/d	0,5						1,5			2,0			
	d/d		0,6						1,5			2,0			
8 N/mm <sup>2</sup>	w/w	w/d	0,75						2,0			2,5			
	d/d		0,75						2,0			2,5			
10 N/mm <sup>2</sup>	w/w	w/d	0,9						2,5			3,0			
	d/d		0,9						2,5			3,5			
12 N/mm <sup>2</sup>	w/w	w/d	0,9						3,0			3,5			
	d/d		1,2						3,0			4,0			

Factor for temperature range 72/120°C: 0,83

**Table C25.2:** Characteristic resistance under shear load

Anchor rod		M6	M8	M6	M8	-	M8	M10	M8	M10	-	M12	M16	M12	M16	
Internal threaded anchor FIS E		-		-		M6	M8	-		-		M10	M12	-		
						11x85						15x85				
Perforated sleeve FIS H K		12x50		12x85		16x85			16x130		20x85			20x130		
<b><math>V_{Rk} = V_{Rk,b} = V_{Rk,c}</math> [kN] depending on the compressive strength <math>f_b</math> (temperature range 50/80°C and 72/120°C)</b>																
compressive strength $f_b$		use category														
4 N/mm <sup>2</sup>	w/w	w/d	0,5						0,6			0,5			0,6	
	d/d		0,5						0,6			0,5			0,6	
6 N/mm <sup>2</sup>	w/w	w/d	0,75						0,9			0,75			0,9	
	d/d		0,75						0,9			0,75			0,9	
8 N/mm <sup>2</sup>	w/w	w/d	0,9						1,2			0,9			1,2	
	d/d		0,9						1,2			0,9			1,2	
10 N/mm <sup>2</sup>	w/w	w/d	1,2						1,5			1,2			1,5	
	d/d		1,2						1,5			1,2			1,5	
12 N/mm <sup>2</sup>	w/w	w/d	1,5						2,0			1,5			2,0	
	d/d		1,5						2,0			1,5			2,0	

Factor for job site tests and displacements see annex C110

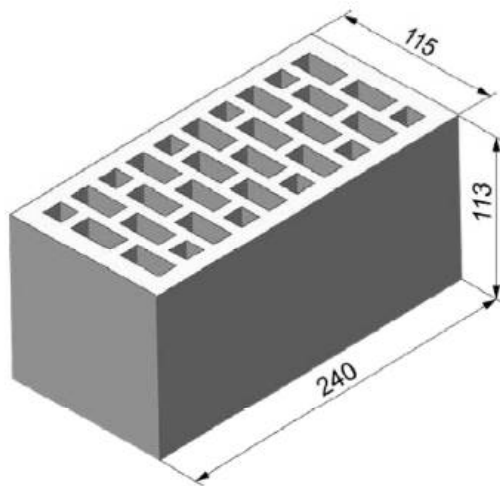
fischer injection system FIS V Plus for masonry

**Performance**

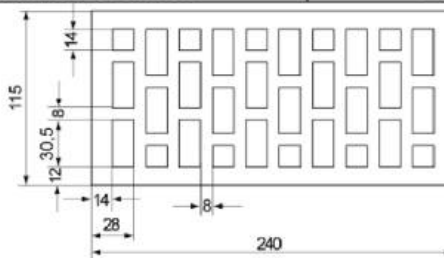
Vertical perforated brick HLz, Characteristic resistance under tension and shear load

**Annex C 25**

**Vertical perforated brick HLz, 2DF, EN 771-1:2015**



Vertical perforated brick HLz, 2DF, EN 771-1:2015			
Producer	e.g. Wienerberger		
Nominal dimensions [mm]	length L	width W	height H
	240	115	113
Density $\rho$ [kg/dm <sup>3</sup> ]	≥ 1,4		
Compressive strength $f_b$ [N/mm <sup>2</sup> ]	6 / 10 / 16 / 20 / 28		
Standard or annex	EN 771-1:2015		



Dimension see also Annex B 15

**Table C26.1: Installation parameters**

<b>Anchor rod</b>	M6	M8	M6	M8	-	M8	M10	-	M12	M16
<b>Internal threaded anchor FIS E</b>	-		-		M6	M8	-		M10	M12
	-		-		11x85		-		15x85	
<b>Perforated sleeve FIS H K</b>	12x50		12x85		16x85			20x85		
<b>Anchor rod and internal threaded anchor FIS E with perforated sleeve FIS H K</b>										
Max. installation torque $T_{inst}$ [Nm]	2									
<b>General installation parameters</b>										
Edge distance $c_{min}$	80									
Spacing	$s_{cr \parallel} = s_{min \parallel}$ [mm]		240							
	$s_{cr \perp} = s_{min \perp}$		115							
<b>Drilling method</b>										
Hammer drilling with hard metal hammer drill										

**Table C26.2: Group factors**

<b>Anchor rod</b>	M6	M8	M6	M8	-	M8	M10	-	M12	M16
<b>Internal threaded anchor FIS E</b>	-		-		M6	M8	-		M10	M12
	-		-		11x85		-		15x85	
<b>Perforated sleeve FIS H K</b>	12x50		12x85		16x85			20x85		
Group factors	$\alpha_{g,N \parallel}$	[-]	2							
	$\alpha_{g,V \parallel}$									
	$\alpha_{g,N \perp}$									
	$\alpha_{g,V \perp}$									

fischer injection system FIS V Plus for masonry

**Performance**  
Vertical perforated brick HLz, 2DF, dimensions, installation parameters

**Annex C 26**

### Vertical perforated brick HLz, 2DF, EN 771-1:2015

**Table C27.1:** Characteristic resistance under tension load

Anchor rod	M6	M8	M6	M8	-	M8	M10	-	M12	M16	
Internal threaded anchor FIS E	-		-		M6	M8	-		M10	M12	-
					11x85				15x85		
Perforated sleeve FIS H K	12x50		12x85		16x85			20x85			
<b><math>N_{Rk} = N_{Rk,p} = N_{Rk,b}</math> [kN] depending on the compressive strength <math>f_b</math> (temperature range 50/80°C)</b>											
compressive strength $f_b$	use category										
6 N/mm <sup>2</sup>	w/w	w/d	0,75	0,9	0,75			0,9			
	d/d		0,75	1,2	0,75			0,9			
10 N/mm <sup>2</sup>	w/w	w/d	1,2	1,5	1,2			1,5			
	d/d		1,2	2,0	1,2			1,5			
16 N/mm <sup>2</sup>	w/w	w/d	2,0	2,5	2,0			2,0			
	d/d		2,0	3,0	2,0			2,5			
20 N/mm <sup>2</sup>	w/w	w/d	2,5	3,5	2,5			3,0			
	d/d		2,5	4,0	2,5			3,0			
28 N/mm <sup>2</sup>	w/w	w/d	3,0	5,0	3,5			4,0			
	d/d		3,5	5,5	3,5			4,5			

Factor for temperature range 72/120°C: 0,83

**Table C27.2:** Characteristic resistance under shear load

Anchor rod	M6	M8	M6	M8	-	M8	M10	-	M12	M16	
Internal threaded anchor FIS E	-		-		M6	M8	-		M10	M12	-
					11x85				15x85		
Perforated sleeve FIS H K	12x50		12x85		16x85			20x85			
<b><math>V_{Rk} = V_{Rk,b} = V_{Rk,c}</math> [kN] depending on the compressive strength <math>f_b</math> (temperature range 50/80°C and 72/120°C)</b>											
compressive strength $f_b$	use category										
6 N/mm <sup>2</sup>	w/w	w/d	1,2	1,5	1,2	2,0	1,2	1,5	2,5		
	d/d										
10 N/mm <sup>2</sup>	w/w	w/d	2,0	2,5	2,0	4,0	2,0	2,5	4,5		
	d/d										
16 N/mm <sup>2</sup>	w/w	w/d	3,0	3,5	3,0	6,0	3,0	3,5	7,0		
	d/d										
20 N/mm <sup>2</sup>	w/w	w/d	4,0	4,5	4,0	7,5	4,0	4,5	8,5		
	d/d										
28 N/mm <sup>2</sup>	w/w	w/d	5,0	6,5	5,0	9,5	5,0	6,5	12,0		
	d/d										

Factor for job site tests and displacements see annex C110

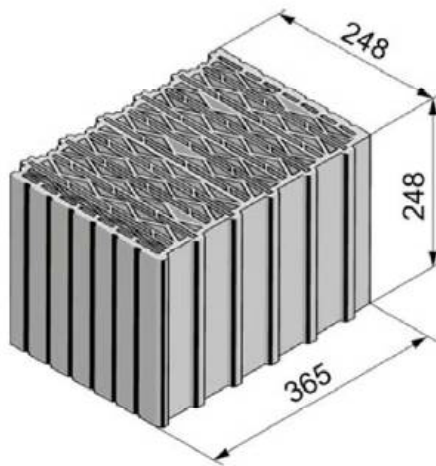
fischer injection system FIS V Plus for masonry

**Performance**  
Vertical perforated brick HLz, 2DF,  
Characteristic resistance under tension and shear load

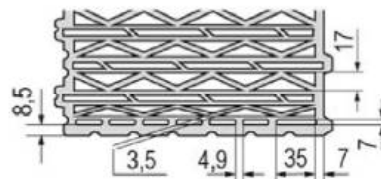
**Annex C 27**



**Vertical perforated brick HLz, T8, EN 771-1:2015**



Vertical perforated brick HLz, T8, EN 771-1:2015			
Producer	-		
Nominal dimensions [mm]	length L	width W	height H
	248	365	248
Density $\rho$ [kg/dm <sup>3</sup> ]	0,6		
Compressive strength $f_b$ [N/mm <sup>2</sup> ]	4 / 6 / 8		
Standard or annex	EN 771-1:2015		



Dimension see also Annex B 15

**Table C28.1:** Installation parameters  
(Pre-positioned anchorage with perforated sleeve FIS H K)

Anchor rod	M6	M8	M6	M8	-	M8	M10	M8	M10	-	M12	M16	M12	M16	M12	M16		
Internal threaded anchor FIS E	-	-	-	-	M6 M8 11x85	-	-	-	-	M10 M12 15x85	-	-	-	-	-	-		
Perforated sleeve FIS H K	12x50		12x85		16x85			16x130		20x85		20x130		20x200				
Anchor rod and internal threaded anchor FIS E with perforated sleeve FIS H K																		
Max. installation torque $T_{inst}$ [Nm]	3	5	3	5	3	5	5											
<b>General installation parameters</b>																		
Edge distance $C_{min}$							60											
Spacing	$S_{min \parallel}$							80										
	$S_{cr \parallel}$							250										
	$S_{min \perp}$							80										
	$S_{cr \perp}$							250										
<b>Drilling method</b>																		
Rotary drilling with carbide drill																		

**Table C28.2:** Group factors

Anchor rod	M6	M8	M6	M8	-	M8	M10	M8	M10	-	M12	M16	M12	M16	M12	M16		
Internal threaded anchor FIS E	-	-	-	-	M6 M8 11x85	-	-	-	-	M10 M12 15x85	-	-	-	-	-	-		
Perforated sleeve FIS H K	12x50		12x85		16x85			16x130		20x85		20x130		20x200				
Group factors	$\alpha_{g,N \parallel}$							1,3										
	$\alpha_{g,V \parallel}$							1,2										
	$\alpha_{g,N \perp}$							1,3										
	$\alpha_{g,V \perp}$							1,0										

fischer injection system FIS V Plus for masonry

**Performance**  
Vertical perforated brick HLz, T8, dimensions, installation parameters

**Annex C 28**

**Vertical perforated brick HLz, T8, EN 771-1:2015**

**Table C29.1:** Installation parameters  
(Push through anchorage with perforated sleeve FIS H K)

Anchor rod		M10	M12	M16
Perforated sleeve FIS H K		18x130/200		22x130/200
Anchor rod with perforated sleeve FIS H K				
Max. installation torque	$T_{inst}$ [Nm]	5		
<b>General installation parameters</b>				
Edge distance	$c_{min}$	60		
Spacing	$s_{min \parallel}$	80		
	$s_{cr \parallel}$ [mm]	250		
	$s_{min \perp}$	80		
	$s_{cr \perp}$	250		
<b>Drilling method</b>				
Rotary drilling with carbide drill				

**Table C29.2:** Group factors

Anchor rod		M10	M12	M16
Perforated sleeve FIS H K		18x130/200		22x130/200
Group factors	$\alpha_{g,N \parallel}$	1,3		
	$\alpha_{g,V \parallel}$	1,2		
	$\alpha_{g,N \perp}$	1,3		
	$\alpha_{g,V \perp}$	1,0		

fischer injection system FIS V Plus for masonry

**Performance**  
Vertical perforated brick HLz, T8, dimensions, installation parameters

**Annex C 29**

### Vertical perforated brick HLz, T8, EN 771-1:2015

**Table C30.1:** Characteristic resistance under tension load (Pre-positioned anchorage)

Anchor rod	M6	M8	M6	M8	-	M8	M10	M8	M10	-	M12	M16	M12	M16	M12	M16		
Internal threaded anchor FIS E	-	-	-	-	M6 M8	-	-	-	-	M10 M12	-	-	-	-	-	-		
Perforated sleeve FIS H K	12x50		12x85		16x85			16x130			20x85		20x130		20x200			
<b><math>N_{Rk} = N_{Rk,p} = N_{Rk,b}</math> [kN] depending on the compressive strength <math>f_b</math> (temperature range 50/80°C)</b>																		
compressive strength $f_b$	use category																	
4 N/mm <sup>2</sup>	w/w	w/d	1,2														1,2	
	d/d		1,2														1,5	
6 N/mm <sup>2</sup>	w/w	w/d	1,5														1,5	
	d/d		1,5														1,5	
8 N/mm <sup>2</sup>	w/w	w/d	1,5														2,0	
	d/d		2,0														2,0	

**Table C30.2:** Characteristic resistance under tension load (Push through anchorage)

Anchor rod	M10		M12		M16			
Perforated sleeve FIS H K	18x130/200				22x130/200			
<b><math>N_{Rk} = N_{Rk,p} = N_{Rk,b}</math> [kN] depending on the compressive strength <math>f_b</math> (temperature range 50/80°C)</b>								
compressive strength $f_b$	use category							
4 N/mm <sup>2</sup>	w/w	w/d					1,2	
	d/d						1,5	
6 N/mm <sup>2</sup>	w/w	w/d					1,5	
	d/d						1,5	
8 N/mm <sup>2</sup>	w/w	w/d					2,0	
	d/d						2,0	

Factor for job site tests and displacements see annex C110

Factor for temperature range 72/120°C: 0,83

fischer injection system FIS V Plus for masonry

**Performance**

Vertical perforated brick HLz, T8, Characteristic resistance under tension load

**Annex C 30**

**Vertical perforated brick HLz, T8, EN 771-1:2015**

**Table C31.1:** Characteristic resistance under shear load (Pre-positioned anchorage)

Anchor rod	M6	M8	M6	M8	-	M8	M10	M8	M10	-	M12	M16	M12	M16	M12	M16
Internal threaded anchor FIS E	-	-	-	-	M6	M8	-	-	M10	M12	-	-	-	-	-	-
Perforated sleeve FIS H K	12x50		12x85		16x85			16x130		20x85			20x130		20x200	

$V_{Rk} = V_{Rk,b} = V_{Rk,c}$  [kN] depending on the compressive strength  $f_b$  (temperature range 50/80°C and 72/120°C)

compressive strength $f_b$	use category		
	w/w	w/d	
4 N/mm <sup>2</sup>	w/w	w/d	1,2
	d/d		
6 N/mm <sup>2</sup>	w/w	w/d	1,5
	d/d		
8 N/mm <sup>2</sup>	w/w	w/d	1,5
	d/d		

**Table C31.2:** Characteristic resistance under shear load (Push through anchorage)

Anchor rod	M10	M12	M16
Perforated sleeve FIS H K	18x130/200		22x130/200

$V_{Rk} = V_{Rk,b} = V_{Rk,c}$  [kN] depending on the compressive strength  $f_b$  (temperature range 50/80°C and 72/120°C)

compressive strength $f_b$	use category		
	w/w	w/d	
4 N/mm <sup>2</sup>	w/w	w/d	1,2
	d/d		
6 N/mm <sup>2</sup>	w/w	w/d	1,5
	d/d		
8 N/mm <sup>2</sup>	w/w	w/d	1,5
	d/d		

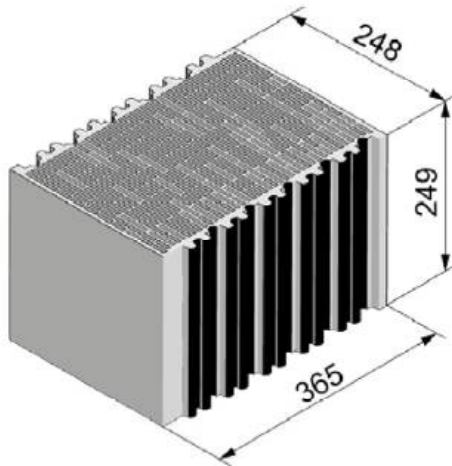
Factor for job site tests and displacements see annex C108

fischer injection system FIS V Plus for masonry

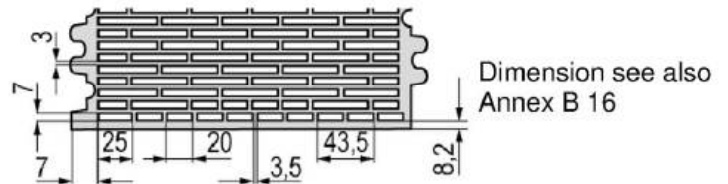
**Performance**  
Vertical perforated brick HLz, T8, Characteristic resistance under shear load

**Annex C 31**

**Vertical perforated brick HLz, T10, T11, EN 771-1:2015**



Vertical perforated brick HLz, T10, T11, EN 771-1:2015			
Producer	-		
Nominal dimensions [mm]	length L	width W	height H
	248	365	249
Density $\rho$ [kg/dm <sup>3</sup> ]	0,7		
Compressive strength $f_b$ [N/mm <sup>2</sup> ]	8 / 10 / 12		
Standard or annex	EN 771-1:2015		



**Table C32.1:** Installation parameters  
(Pre-positioned anchorage with perforated sleeve FIS H K)

<b>Anchor rod</b>	M6	M8	M6	M8	-	M8	M10	M8	M10	-	M12	M16	M12	M16	M12	M16
<b>Internal threaded anchor FIS E</b>	-	-	-	-	M6	M8	-	-	M10	M12	-	-	-	-	-	-
<b>Perforated sleeve FIS H K</b>	12x50		12x85		16x85		16x130		20x85		20x130		20x200		-	-
<b>Anchor rod and internal threaded anchor FIS E with perforated sleeve FIS H K</b>																
Max. installation torque	$T_{inst}$ [Nm]	3				5		3		5						
<b>General installation parameters</b>																
Edge distance	$c_{min}$							60								
Spacing	$s_{min \parallel}$							80								
	$s_{cr \parallel}$							250								
	$s_{min \perp}$							80								
	$s_{cr \perp}$							250								
<b>Drilling method</b>																
Rotary drilling with carbide drill																

**Table C32.2:** Group factors

<b>Anchor rod</b>	M6	M8	M6	M8	-	M8	M10	M8	M10	-	M12	M16	M12	M16	M12	M16
<b>Internal threaded anchor FIS E</b>	-	-	-	-	M6	M8	-	-	M10	M12	-	-	-	-	-	-
<b>Perforated sleeve FIS H K</b>	12x50		12x85		16x85		16x130		20x85		20x130		20x200		-	-
Group factors	$\alpha_{g,N \parallel}$							1,7								
	$\alpha_{g,V \parallel}$							0,5								
	$\alpha_{g,N \perp}$							1,3								
	$\alpha_{g,V \perp}$							0,5								

fischer injection system FIS V Plus for masonry

**Performance**  
Vertical perforated brick HLz, T10, T11, dimensions, installation parameters

**Annex C 32**



### Vertical perforated brick HLz, T10, T11, EN 771-1:2015

**Table C33.1:** Installation parameters  
(Push through anchorage with perforated sleeve FIS H K)

Anchor rod		M10	M12	M16
Perforated sleeve FIS H K		18x130/200		22x130/200
Anchor rod with perforated sleeve FIS H K				
Max. installation torque	$T_{inst}$ [Nm]	5		
<b>General installation parameters</b>				
Edge distance	$c_{min}$	60		
Spacing	$s_{min \parallel}$	80		
	$s_{cr \parallel}$ [mm]	250		
	$s_{min \perp}$	80		
	$s_{cr \perp}$	250		
<b>Drilling method</b>				
Rotary drilling with carbide drill				

**Table C33.2:** Group factors

Anchor rod		M10	M12	M16
Perforated sleeve FIS H K		18x130/200		22x130/200
Group factors	$\alpha_{g,N \parallel}$	1,7		
	$\alpha_{g,V \parallel}$	0,5		
	$\alpha_{g,N \perp}$	1,3		
	$\alpha_{g,V \perp}$	0,5		

fischer injection system FIS V Plus for masonry

**Performance**  
Vertical perforated brick HLz, T10, T11, dimensions, installation parameters

**Annex C 33**

### Vertical perforated brick HLz, T10, T11, EN 771-1:2015

**Table C34.1:** Characteristic resistance under tension load (Pre-positioned anchorage)

Anchor rod	M6	M8	M6	M8	-	M8	M10	M8	M10	-	M12	M16	M12	M16	M12	M16		
Internal threaded anchor FIS E	-	-	-	-	M6 M8 11x85	-	-	-	-	M10 M12 15x85	-	-	-	-	-	-		
Perforated sleeve FIS H K	12x50		12x85		16x85			16x130		20x85			20x130		20x200			
<b><math>N_{Rk} = N_{Rk,p} = N_{Rk,b}</math> [kN] depending on the compressive strength <math>f_b</math> (temperature range 50/80°C)</b>																		
compressive strength $f_b$	use category																	
8 N/mm <sup>2</sup>	w/w	w/d	1,5				1,5											
	d/d		1,5				2,0											
10 N/mm <sup>2</sup>	w/w	w/d	1,5				2,0											
	d/d		2,0				2,0											
12 N/mm <sup>2</sup>	w/w	w/d	2,0				2,0											
	d/d		2,0				2,5											

**Table C34.2:** Characteristic resistance under tension load (Push through anchorage)

Anchor rod	M10		M12		M16	
Perforated sleeve FIS H K	18x130/200				22x130/200	
<b><math>N_{Rk} = N_{Rk,p} = N_{Rk,b}</math> [kN] depending on the compressive strength <math>f_b</math> (temperature range 50/80°C)</b>						
compressive strength $f_b$	use category					
8 N/mm <sup>2</sup>	w/w	w/d	1,5		1,5	
	d/d		2,0		2,0	
10 N/mm <sup>2</sup>	w/w	w/d	2,0		2,0	
	d/d		2,0		2,0	
12 N/mm <sup>2</sup>	w/w	w/d	2,0		2,0	
	d/d		2,5		2,5	

Factor for job site tests and displacements see annex C110

Factor for temperature range 72/120°C: 0,83

fischer injection system FIS V Plus for masonry

**Performance**

Vertical perforated brick HLz, T10, T11, Characteristic resistance under tension load

**Annex C 34**

### Vertical perforated brick HLz, T10, T11, EN 771-1:2015

**Table C35.1:** Characteristic resistance under shear load (Pre-positioned anchorage)

Anchor rod	M6	M8	M6	M8	-	M8	M10	M8	M10	-	M12	M16	M12	M16	M12	M16
Internal threaded anchor FIS E	-	-	-	-	M6	M8	-	-	M10	M12	-	-	-	-	-	-
					11x85				15x85							
Perforated sleeve FIS H K	12x50		12x85		16x85			16x130		20x85			20x130		20x200	

$V_{Rk} = V_{Rk,b} = V_{Rk,c}$  [kN] depending on the compressive strength  $f_b$  (temperature range 50/80°C and 72/120°C)

compressive strength $f_b$	use category		0,9	1,5	2,0
	w/w	w/d			
8 N/mm <sup>2</sup>	w/w	w/d	0,9	1,5	2,0
	d/d				
10 N/mm <sup>2</sup>	w/w	w/d	0,9	1,5	2,0
	d/d				
12 N/mm <sup>2</sup>	w/w	w/d	1,2	2,0	2,0
	d/d				

**Table C35.2:** Characteristic resistance under shear load (Push through anchorage)

Anchor rod	M10	M12	M16
Perforated sleeve FIS H K	18x130/200		22x130/200

$V_{Rk} = V_{Rk,b} = V_{Rk,c}$  [kN] depending on the compressive strength  $f_b$  (temperature range 50/80°C and 72/120°C)

compressive strength $f_b$	use category		1,5	2,0
	w/w	w/d		
8 N/mm <sup>2</sup>	w/w	w/d	1,5	2,0
	d/d			
10 N/mm <sup>2</sup>	w/w	w/d	1,5	2,0
	d/d			
12 N/mm <sup>2</sup>	w/w	w/d	2,0	2,0
	d/d			

Factor for job site tests and displacements see annex C110

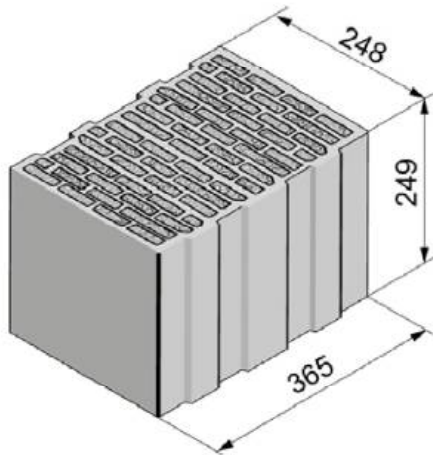
fischer injection system FIS V Plus for masonry

**Performance**

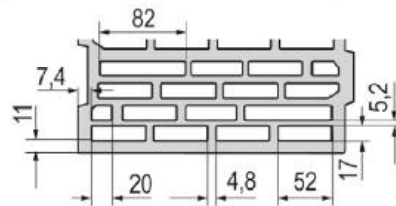
Vertical perforated brick HLz, T10, T11, Characteristic resistance under shear load

**Annex C 35**

**Vertical perforated brick HLz, T7 PF, filled with perlite, EN 771-1:2015**



Vertical perforated brick HLz, T7 PF, filled with perlite, EN 771-1:2015			
Producer	-		
Nominal dimensions [mm]	length L	width W	height H
	248	365	249
Density $\rho$ [kg/dm <sup>3</sup> ]	0,5		
Compressive strength $f_b$ [N/mm <sup>2</sup> ]	4 / 6		
Standard or annex	EN 771-1:2015		



Dimension see also Annex B 16

**Table C36.1:** Installation parameters  
(Pre-positioned anchorage with perforated sleeve FIS H K)

Anchor rod	M6	M8	M6	M8	-	M8	M10	M8	M10	-	M12	M16	M12	M16	M12	M16
Internal threaded anchor FIS E	-	-	-	-	M6	M8	-	-	M10	M12	-	-	-	-	-	-
					11x85				15x85							
Perforated sleeve FIS H K	12x50	12x85	12x85	16x85	16x130	20x85	20x130	20x200								

**Ankerstangen und Innengewindeanker FIS E mit Injektionsanker-Hülse FIS H K**

Max. installation torque	$T_{inst}$ [Nm]	2	5	2	5
--------------------------	-----------------	---	---	---	---

**General installation parameters**

Edge distance	$c_{min}$	60	
	$s_{min} \parallel$	80	
	Spacing	$s_{cr} \parallel$ [mm]	250
		$s_{min} \perp$	80
		$s_{cr} \perp$	250

**Drilling method**

Rotary drilling with carbide drill

**Table C36.2:** Group factors

Anchor rod	M6	M8	M6	M8	-	M8	M10	M8	M10	-	M12	M16	M12	M16	M12	M16
Internal threaded anchor FIS E	-	-	-	-	M6	M8	-	-	M10	M12	-	-	-	-	-	-
					11x85				15x85							
Perforated sleeve FIS H K	12x50	12x85	12x85	16x85	16x130	20x85	20x130	20x200								
Group factors	$\alpha_{g,N} \parallel$						1,1									
	$\alpha_{g,V} \parallel$						1,2									
	$\alpha_{g,N} \perp$						1,1									
	$\alpha_{g,V} \perp$						1,2									

fischer injection system FIS V Plus for masonry

**Performance**  
Vertical perforated brick HLz, T7 PF, filled with perlite, dimensions, installation parameters

**Annex C 36**

**Vertical perforated brick HLz, T7 PF, filled with perlite, EN 771-1:2015**

**Table C37.1:** Installation parameters  
(Push through anchorage with perforated sleeve FIS H K)

Anchor rod		M10	M12	M16
Perforated sleeve FIS H K		18x130/200		22x130/200
Anchor rod with perforated sleeve FIS H K				
Max. installation torque	$T_{inst}$ [Nm]	5		
<b>General installation parameters</b>				
Edge distance	$c_{min}$	60		
Spacing	$s_{min \parallel}$	80		
	$s_{cr \parallel}$ [mm]	250		
	$s_{min \perp}$	80		
	$s_{cr \perp}$	250		
<b>Drilling method</b>				
Rotary drilling with carbide drill				

**Table C37.2:** Group factors

Anchor rod		M10	M12	M16
Perforated sleeve FIS H K		18x130/200		22x130/200
Group factors	$\alpha_{g,N \parallel}$	1,1		
	$\alpha_{g,V \parallel}$	1,2		
	$\alpha_{g,N \perp}$	1,1		
	$\alpha_{g,V \perp}$	1,2		

fischer injection system FIS V Plus for masonry

**Performance**  
Vertical perforated brick HLz, T7 PF, filled with perlite,  
dimensions, installation parameters

**Annex C 37**



**Vertical perforated brick HLz, T7 PF, filled with perlite, EN 771-1:2015**

**Table C38.1:** Characteristic resistance under tension load (Pre-positioned anchorage)

Anchor rod	M6	M8	M6	M8	-	M8	M10	M8	M10	-	M12	M16	M12	M16	M12	M16
Internal threaded anchor FIS E	-	-	-	-	M6	M8	-	-	-	M10	M12	-	-	-	-	-
					11x85					15x85						
Perforated sleeve FIS H K	12x50		12x85		16x85			16x130		20x85			20x130		20x200	
<b><math>N_{Rk} = N_{Rk,p} = N_{Rk,b}</math> [kN] depending on the compressive strength <math>f_b</math> (temperature range 50/80°C)</b>																
compressive strength $f_b$	use category															
4 N/mm <sup>2</sup>	w/w	w/d	1,2				1,2		1,2			1,2		2,0		
	d/d		1,5				1,5		1,5			1,5		2,0		
6 N/mm <sup>2</sup>	w/w	w/d	1,5				1,5		1,5			1,5		2,5		
	d/d		1,5				2,0		1,5			2,0		3,0		

**Table C38.2:** Characteristic resistance under tension load (Push through anchorage)

Anchor rod	M10		M12		M16	
Perforated sleeve FIS H K	18x130/200				22x130/200	
<b><math>N_{Rk} = N_{Rk,p} = N_{Rk,b}</math> [kN] depending on the compressive strength <math>f_b</math> (temperature range 50/80°C)</b>						
compressive strength $f_b$	use category					
4 N/mm <sup>2</sup>	w/w	w/d	1,2		1,2	
	d/d		1,5		1,5	
6 N/mm <sup>2</sup>	w/w	w/d	1,5		1,5	
	d/d		2,0		2,0	

Factor for job site tests and displacements see annex C110

Factor for temperature range 72/120°C: 0,83

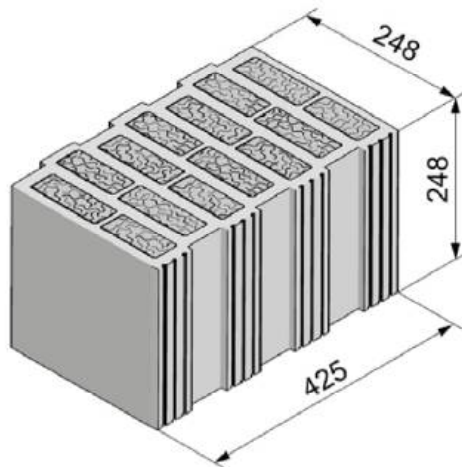
fischer injection system FIS V Plus for masonry

**Performance**  
Vertical perforated brick HLz, T7 PF, filled with perlite,  
Characteristic resistance under tension load

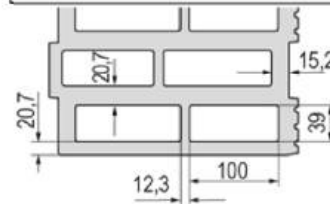
**Annex C 38**

<b>Vertical perforated brick HLz, T7 PF, filled with perlite, EN 771-1:2015</b>															
<b>Table C39.1: Characteristic resistance under shear load (Pre-positioned anchorage)</b>															
Anchor rod	M6	M8	M6	M8	-	M8	M10	M8	M10	-	M12	M16	M12	M16	
Internal threaded anchor FIS E	-		-		M6	M8	-		-		M10	M12	-		
					11x85						15x85				
Perforated sleeve FIS H K	12x50		12x85		16x85			16x130		20x85			20x130		20x200
<b><math>V_{Rk} = V_{Rk,b} = V_{Rk,c}</math> [kN] depending on the compressive strength <math>f_b</math> (temperature range 50/80°C and 72/120°C)</b>															
compressive strength $f_b$	use category														
	w/w	w/d	0,9			1,5			1,2						
6 N/mm <sup>2</sup>	w/w	w/d	1,2			2,0			1,5						
	d/d														
<b>Table C39.2: Characteristic resistance under shear load (Push through anchorage)</b>															
Anchor rod	M10				M12				M16						
Perforated sleeve FIS H K	18x130/200				22x130/200										
<b><math>V_{Rk} = V_{Rk,b} = V_{Rk,c}</math> [kN] depending on the compressive strength <math>f_b</math> (temperature range 50/80°C and 72/120°C)</b>															
compressive strength $f_b$	use category														
	w/w	w/d	1,5			1,2									
6 N/mm <sup>2</sup>	w/w	w/d	2,0			1,5									
	d/d														
Factor for job site tests and displacements see annex C110															
fischer injection system FIS V Plus for masonry												<b>Annex C 39</b>			
<b>Performance</b> Vertical perforated brick HLz, T7 PF, filled with perlite, Characteristic resistance under shear load															

**Vertical perforated brick HLz, S9 MW, filled with mineral wool, EN 771-1:2015**



Vertical perforated brick HLz, S9 MW, filled with mineral wool, EN 771-1:2015			
Producer	-		
Nominal dimensions [mm]	length L	width W	height H
	248	425	248
Density $\rho$ [kg/dm <sup>3</sup> ]	0,8		
Compressive strength $f_b$ [N/mm <sup>2</sup> ]	4 / 6 / 8		
Standard or annex	EN 771-1:2015		



Dimension see also Annex B 16

**Table C40.1:** Installation parameters  
(Pre-positioned anchorage with perforated sleeve FIS H K)

Anchor rod	M6	M8	M6	M8	-	M8	M10	M8	M10	-	M12	M16	M12	M16	M12	M16	
Internal threaded anchor FIS E	-	-	-	-	M6 11x85	M8	-	-	-	M10 15x85	M12	-	-	-	-	-	
Perforated sleeve FIS H K	12x50		12x85		16x85			16x130			20x85		20x130			20x200	
Anchor rod and internal threaded anchor FIS E with perforated sleeve FIS H K																	
Max. installation torque	$T_{inst}$ [Nm]	3				5		3		5							
<b>General installation parameters</b>																	
Edge distance	$c_{min}$											60					
Spacing	$s_{min \parallel}$											80					
	$s_{cr \parallel}$											250					
	$s_{min \perp}$											80					
	$s_{cr \perp}$											250					
<b>Drilling method</b>																	
Rotary drilling with carbide drill																	

**Table C40.2:** Group factors

Anchor rod	M6	M8	M6	M8	-	M8	M10	M8	M10	-	M12	M16	M12	M16	M12	M16	
Internal threaded anchor FIS E	-	-	-	-	M6 11x85	M8	-	-	-	M10 15x85	M12	-	-	-	-	-	
Perforated sleeve FIS H K	12x50		12x85		16x85			16x130			20x85		20x130			20x200	
Group factors	$\alpha_{g,N \parallel}$											1,3					
	$\alpha_{g,V \parallel}$											1,2					
	$\alpha_{g,N \perp}$											0,6					
	$\alpha_{g,V \perp}$											1,2					

fischer injection system FIS V Plus for masonry

**Performance**  
Vertical perforated brick HLz, S9 MW, filled with mineral wool, dimensions, installation parameters

**Annex C 40**

**Vertical perforated brick HLz, S9 MW, filled with mineral wool, EN 771-1:2015**

**Table C41.1: Installation parameters**  
(Push through anchorage with perforated sleeve FIS H K)

Anchor rod		M10	M12	M16
Perforated sleeve FIS H K		18x130/200		22x130/200
Anchor rod with perforated sleeve FIS H K				
Max. installation torque	$T_{inst}$	[Nm]	5	
<b>General installation parameters</b>				
Edge distance	$c_{min}$		60	
	$s_{min \parallel}$		80	
Spacing	$s_{cr \parallel}$	[mm]	250	
	$s_{min \perp}$		80	
	$s_{cr \perp}$		250	
<b>Drilling method</b>				
Rotary drilling with carbide drill				

**Table C41.2: Group factors**

Anchor rod		M10	M12	M16
Perforated sleeve FIS H K		18x130/200		22x130/200
Group factors	$\alpha_{g,N \parallel}$	[-]	1,3	
	$\alpha_{g,V \parallel}$		1,2	
	$\alpha_{g,N \perp}$		0,6	
	$\alpha_{g,V \perp}$		1,2	

fischer injection system FIS V Plus for masonry

**Performance**  
Vertical perforated brick HLz, S9 MW, filled with mineral wool,  
dimensions, installation parameters

**Annex C 41**

**Vertical perforated brick HLz, S9 MW, filled with mineral wool, EN 771-1:2015**

**Table C42.1:** Characteristic resistance under tension load (Pre-positioned anchorage)

Anchor rod	M6	M8	M6	M8	-	M8	M10	M8	M10	-	M12	M16	M12	M16	M12	M16		
Internal threaded anchor FIS E	-	-	-	-	M6 M8 11x85	-	-	-	-	M10 M12 15x85	-	-	-	-	-	-		
Perforated sleeve FIS H K	12x50		12x85		16x85			16x130		20x85			20x130		20x200			
<b><math>N_{Rk} = N_{Rk,p} = N_{Rk,b}</math> [kN] depending on the compressive strength <math>f_b</math> (temperature range 50/80°C)</b>																		
compressive strength $f_b$	use category																	
4 N/mm <sup>2</sup>	w/w	w/d	1,5				2,0			3,0		2,5			4,0			
	d/d		2,0				2,5			3,0		2,5			4,5			
6 N/mm <sup>2</sup>	w/w	w/d	2,0				2,5			3,5		3,0			5,0			
	d/d		2,0				3,0			4,0		3,0			5,5			
8 N/mm <sup>2</sup>	w/w	w/d	2,5				3,0			4,0		3,5			6,0			
	d/d		2,5				3,0			4,5		3,5			6,5			

**Table C42.2:** Characteristic resistance under tension load (Push through anchorage)

Anchor rod	M10				M12				M16			
Perforated sleeve FIS H K	18x130/200								22x130/200			
<b><math>N_{Rk} = N_{Rk,p} = N_{Rk,b}</math> [kN] depending on the compressive strength <math>f_b</math> (temperature range 50/80°C)</b>												
compressive strength $f_b$	use category											
4 N/mm <sup>2</sup>	w/w	w/d	3,0				4,0					
	d/d		3,0				4,5					
6 N/mm <sup>2</sup>	w/w	w/d	3,5				5,0					
	d/d		4,0				5,5					
8 N/mm <sup>2</sup>	w/w	w/d	4,0				6,0					
	d/d		4,5				6,5					

Factor for job site tests and displacements see annex C110

Factor for temperature range 72/120°C: 0,83

fischer injection system FIS V Plus for masonry

**Performance**

Vertical perforated brick HLz, S9 MW, filled with mineral wool;  
Characteristic resistance under tension load

**Annex C 42**



**Vertical perforated brick HLz, S9 MW, filled with mineral wool, EN 771-1:2015**

**Table C43.1: Characteristic resistance under shear load (Pre-positioned anchorage)**

Anchor rod	M6	M8	M6	M8	-	M8	M10	M8	M10	-	M12	M16	M12	M16	M12	M16
Internal threaded anchor FIS E	-	-	-	-	M6	M8	-	-	M10	M12	-	-	-	-	-	-
					11x85				15x85							
Perforated sleeve FIS H K	12x50		12x85		16x85			16x130		20x85			20x130		20x200	

$V_{Rk} = V_{Rk,b} = V_{Rk,c}$  [kN] depending on the compressive strength  $f_b$  (temperature range 50/80°C and 72/120°C)

compressive strength $f_b$	use category						
	4 N/mm <sup>2</sup>	w/w	w/d	2,0	2,0	2,5	2,0
d/d							
6 N/mm <sup>2</sup>	w/w	w/d	2,5	2,5	3,0	2,5	2,0
	d/d						
8 N/mm <sup>2</sup>	w/w	w/d	2,5	3,0	4,0	3,0	2,5
	d/d						

**Table C43.2: Characteristic resistance under shear load (Push through anchorage)**

Anchor rod	M10	M12	M16
Perforated sleeve FIS H K	18x130/200		22x130/200

$V_{Rk} = V_{Rk,b} = V_{Rk,c}$  [kN] depending on the compressive strength  $f_b$  (temperature range 50/80°C and 72/120°C)

compressive strength $f_b$	use category			
	4 N/mm <sup>2</sup>	w/w	w/d	2,5
d/d				
6 N/mm <sup>2</sup>	w/w	w/d	3,0	2,5
	d/d			
8 N/mm <sup>2</sup>	w/w	w/d	4,0	3,0
	d/d			

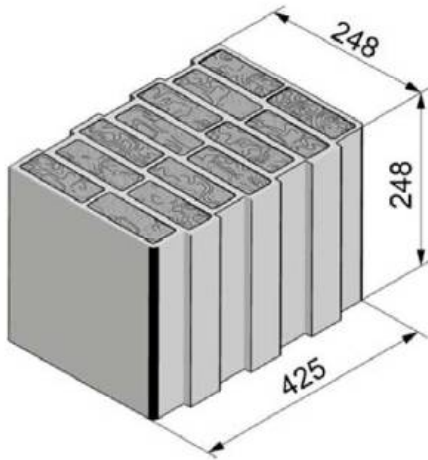
Factor for job site tests and displacements see annex C110

fischer injection system FIS V Plus for masonry

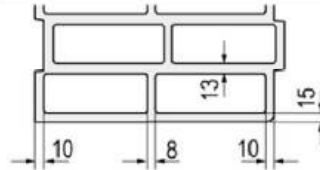
**Performance**  
Vertical perforated brick HLz, S9 MW, filled with mineral wool;  
Characteristic resistance under shear load

**Annex C 43**

**Vertical perforated brick HLz, T7 MW, filled with mineral wool, EN 771-1:2015**



Vertical perforated brick HLz, T7 MW, filled with mineral wool, EN 771-1:2015			
Producer	-		
Nominal dimensions [mm]	length L	width W	height H
	248	425	248
Density $\rho$ [kg/dm <sup>3</sup> ]	0,6		
Compressive strength $f_b$ [N/mm <sup>2</sup> ]	4 / 6 / 8		
Standard or annex	EN 771-1:2015		



Dimension see also Annex B 16

**Table C44.1: Installation parameters**  
(Pre-positioned anchorage with perforated sleeve FIS H K)

Anchor rod	M6	M8	M6	M8	-	M8	M10	M8	M10	-	M12	M16	M12	M16	M12	M16
Internal threaded anchor FIS E	-	-	-	-	M6 M8 11x85	-	-	-	-	M10 M12 15x85	-	-	-	-	-	-
Perforated sleeve FIS H K	12x50		12x85		16x85		16x130		20x85			20x130		20x200		
Anchor rod and internal threaded anchor FIS E with perforated sleeve FIS H K																
Max. installation torque	$T_{inst}$ [Nm]	2				5		2		5						
<b>General installation parameters</b>																
Edge distance	$c_{min}$							60								
Spacing	$s_{min \parallel}$							80								
	$s_{cr \parallel}$							250								
	$s_{min \perp}$							80								
	$s_{cr \perp}$							250								
<b>Drilling method</b>																
Rotary drilling with carbide drill																

**Table C44.2: Group factors**

Anchor rod	M6	M8	M6	M8	-	M8	M10	M8	M10	-	M12	M16	M12	M16	M12	M16
Internal threaded anchor FIS E	-	-	-	-	M6 M8 11x85	-	-	-	-	M10 M12 15x85	-	-	-	-	-	-
Perforated sleeve FIS H K	12x50		12x85		16x85		16x130		20x85			20x130		20x200		
Group factors	$\alpha_{g,N \parallel}$							1,9								
	$\alpha_{g,V \parallel}$							0,9								
	$\alpha_{g,N \perp}$							1,0								
	$\alpha_{g,V \perp}$							0,7								

fischer injection system FIS V Plus for masonry

**Performance**  
Vertical perforated brick HLz, T7 MW, filled with mineral wool;  
dimensions, installation parameters

**Annex C 44**

**Vertical perforated brick HLz, T7 MW, filled with mineral wool, EN 771-1:2015**

**Table C45.1: Installation parameters**  
(Push through anchorage with perforated sleeve FIS H K)

Anchor rod		M10	M12	M16
Perforated sleeve FIS H K		18x130/200		22x130/200
Anchor rod with perforated sleeve FIS H K				
Max. installation torque	$T_{inst}$	[Nm]	5	
<b>General installation parameters</b>				
Edge distance	$c_{min}$		60	
Spacing	$s_{min \parallel}$	[mm]	80	
	$s_{cr \parallel}$		250	
	$s_{min \perp}$		80	
	$s_{cr \perp}$		250	
<b>Drilling method</b>				
Rotary drilling with carbide drill				

**Table C45.2: Group factors**

Anchor rod		M10	M12	M16
Perforated sleeve FIS H K		18x130/200		22x130/200
Group factors	$\alpha_{g,N \parallel}$	[-]	1,9	
	$\alpha_{g,V \parallel}$		0,9	
	$\alpha_{g,N \perp}$		1,0	
	$\alpha_{g,V \perp}$		0,7	

fischer injection system FIS V Plus for masonry

**Performance**  
Vertical perforated brick HLz, T7 MW, filled with mineral wool;  
dimensions, installation parameters

**Annex C 45**

**Vertical perforated brick HLz, T7 MW, filled with mineral wool, EN 771-1:2015**

**Table C46.1:** Characteristic resistance under tension load (Pre-positioned anchorage)

Anchor rod	M6	M8	M6	M8	-	M8	M10	M8	M10	-	M12	M16	M12	M16	M12	M16
Internal threaded anchor FIS E	-	-	-	-	M6 M8 11x85	-	-	-	-	M10 M12 15x85	-	-	-	-	-	-
Perforated sleeve FIS H K	12x50		12x85		16x85			16x130		20x85			20x130		20x200	
<b><math>N_{Rk} = N_{Rk,p} = N_{Rk,b}</math> [kN] depending on the compressive strength <math>f_b</math> (temperature range 50/80°C)</b>																
compressive strength $f_b$	use category															
4 N/mm <sup>2</sup>	w/w	w/d	0,6	0,75	1,5			2,0		1,2			2,0		2,0	
	d/d		0,6	0,9	1,5			2,0		1,5			2,0		2,5	
6 N/mm <sup>2</sup>	w/w	w/d	0,75	0,9	1,5			2,0		1,5			2,5		2,5	
	d/d		0,9	0,9	2,0			2,5		2,0			2,5		3,0	
8 N/mm <sup>2</sup>	w/w	w/d	0,9	1,2	2,0			2,5		2,0			2,5		3,0	
	d/d		0,9	1,2	2,0			3,0		2,0			3,0		3,5	

**Table C46.2:** Characteristic resistance under tension load (Push through anchorage)

Anchor rod	M10		M12		M16	
Perforated sleeve FIS H K	18x130/200				22x130/200	
<b><math>N_{Rk} = N_{Rk,p} = N_{Rk,b}</math> [kN] depending on the compressive strength <math>f_b</math> (temperature range 50/80°C)</b>						
compressive strength $f_b$	use category					
4 N/mm <sup>2</sup>	w/w	w/d	2,0		2,0	
	d/d		2,0		2,0	
6 N/mm <sup>2</sup>	w/w	w/d	2,0		2,5	
	d/d		2,5		2,5	
8 N/mm <sup>2</sup>	w/w	w/d	2,5		2,5	
	d/d		3,0		3,0	

Factor for job site tests and displacements see annex C110

Factor for temperature range 72/120°C: 0,83

fischer injection system FIS V Plus for masonry

**Performance**

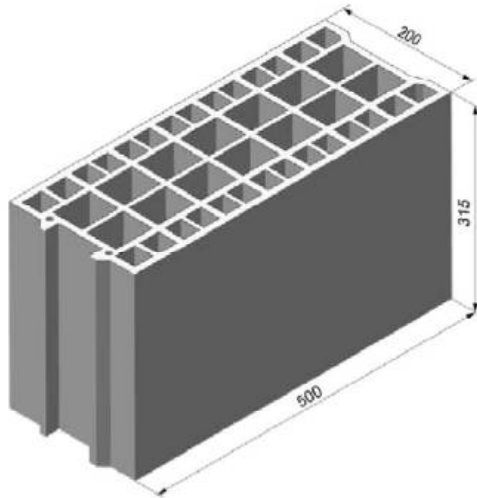
Vertical perforated brick HLz, T7 MW, filled with mineral wool;  
Characteristic resistance under tension load

**Annex C 46**

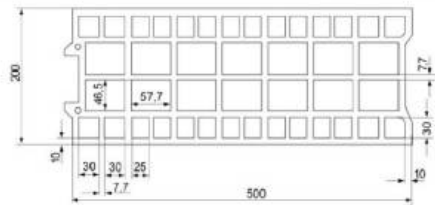
Vertical perforated brick HLz, T7 MW, filled with mineral wool, EN 771-1:2015																
Table C47.1: Characteristic resistance under shear load (Pre-positioned anchorage)																
Anchor rod	M6	M8	M6	M8	-	M8	M10	M8	M10	-	M12	M16	M12	M16	M12	M16
Internal threaded anchor FIS E	-		-		M6	M8	-		-		M10	M12	-		-	
					11x85						15x85					
Perforated sleeve FIS H K	12x50		12x85		16x85			16x130		20x85			20x130		20x200	
<b><math>V_{Rk} = V_{Rk,b} = V_{Rk,c}</math> [kN] depending on the compressive strength <math>f_b</math> (temperature range 50/80°C and 72/120°C)</b>																
compressive strength $f_b$	use category															
4 N/mm <sup>2</sup>	w/w	w/d	1,2			1,5						1,5				
	d/d															
6 N/mm <sup>2</sup>	w/w	w/d	1,5			2,0						1,5				
	d/d															
8 N/mm <sup>2</sup>	w/w	w/d	1,5			2,5						2,0				
	d/d															
Table C47.2: Characteristic resistance under shear load (Push through anchorage)																
Anchor rod	M10				M12				M16							
Perforated sleeve FIS H K	18x130/200								22x130/200							
<b><math>V_{Rk} = V_{Rk,b} = V_{Rk,c}</math> [kN] depending on the compressive strength <math>f_b</math> (temperature range 50/80°C and 72/120°C)</b>																
compressive strength $f_b$	use category															
4 N/mm <sup>2</sup>	w/w	w/d				1,5										
	d/d															
6 N/mm <sup>2</sup>	w/w	w/d				2,0										
	d/d															
8 N/mm <sup>2</sup>	w/w	w/d				2,5										
	d/d															
Factor for job site tests and displacements see annex C110																
fischer injection system FIS V Plus for masonry														Annex C 47		
<b>Performance</b> Vertical perforated brick HLz, T7 MW, filled with mineral wool; Characteristic resistance under shear load																



**Vertical perforated brick HLz, EN 771-1:2015**



Vertical perforated brick HLz, EN 771-1:2015			
Producer	e.g. Bouyer Leroux		
Nominal dimensions [mm]	length L	width W	height H
	500	200	315
Density $\rho$ [kg/dm <sup>3</sup> ]	≥ 0,6		
Compressive strength $f_b$ [N/mm <sup>2</sup> ]	4 / 6 / 8		
Standard or annex	EN 771-1:2015		



Dimension see also Annex B 16

**Table C48.1:** Installation parameters  
(Pre-positioned anchorage with perforated sleeve FIS H K)

Anchor rod	M6	M8	M6	M8	-	M8	M10	M8	M10	-	M12	M16	M12	M16
<b>Internal threaded anchor FIS E</b>	-	-	-	-	M6	M8	-	-	-	M10	M12	-	-	-
					11x85					15x85				
<b>Perforated sleeve FIS H K</b>	12x50		12x85		16x85			16x130		20x85			20x130	
<b>Anchor rod and internal threaded anchor FIS E with perforated sleeve FIS H K</b>														
Max. installation torque	$T_{inst}$	[Nm]	2											
<b>General installation parameters</b>														
Edge distance	$C_{min}$	[mm]	120											
Spacing	$S_{min II}$		120											
	$S_{cr II}$		500											
	$S_{min \perp} = S_{cr \perp}$		315											
<b>Drilling method</b>														
Hammer drilling with hard metal hammer drill														

**Table C48.2:** Group factors

Anchor rod	M6	M8	M6	M8	-	M8	M10	M8	M10	-	M12	M16	M12	M16
<b>Internal threaded anchor FIS E</b>	-	-	-	-	M6	M8	-	-	-	M10	M12	-	-	-
					11x85					15x85				
<b>Perforated sleeve FIS H K</b>	12x50		12x85		16x85			16x130		20x85			20x130	
Group factors	$\alpha_{g,N II}$	[-]	1,3											
	$\alpha_{g,V II}$		1,7											
	$\alpha_{g,N \perp} = \alpha_{g,V \perp}$		2											

fischer injection system FIS V Plus for masonry

**Performance**  
Vertical perforated brick HLz, dimensions, installation parameters

**Annex C 48**

### Vertical perforated brick HLz, EN 771-1:2015

**Table C49.1:** Installation parameters  
(Push through anchorage with perforated sleeve FIS H K)

Anchor rod		M10	M12	M16
Perforated sleeve FIS H K		18x130/200		22x130/200
Anchor rod with perforated sleeve FIS H K				
Max. installation torque	$T_{inst}$ [Nm]	2		
<b>General installation parameters</b>				
Edge distance	$c_{min}$	120		
Spacing	$s_{min \parallel}$	120		
	$s_{cr \parallel}$	500		
	$s_{min \perp} = s_{cr \perp}$	315		
<b>Drilling method</b>				
Hammer drilling with hard metal hammer drill				

**Table C49.2:** Group factors

Anchor rod		M10	M12	M16
Perforated sleeve FIS H K		18x130/200		22x130/200
Group factors	$\alpha_{g,N \parallel}$	1,3		
	$\alpha_{g,V \parallel}$	1,7		
	$\alpha_{g,N \perp} = \alpha_{g,V \perp}$	2		

fischer injection system FIS V Plus for masonry

**Performance**  
Vertical perforated brick HLz, dimensions, installation parameters

**Annex C 49**

### Vertical perforated brick HLz, EN 771-1:2015

**Table C50.1:** Characteristic resistance under tension load (Pre-positioned anchorage)

Anchor rod	M6	M8	M6	M8	-	M8	M10	M8	M10	-	M12	M16	M12	M16
Internal threaded anchor FIS E	-		-		M6	M8	-		-		M10	M12	-	
					11x85						15x85			
Perforated sleeve FIS H K	12x50		12x85		16x85			16x130		20x85			20x130	
<b><math>N_{Rk} = N_{Rk,p} = N_{Rk,b}</math> [kN] depending on the compressive strength <math>f_b</math> (temperature range 50/80°C)</b>														
compressive strength $f_b$	use category													
4 N/mm <sup>2</sup>	w/w	w/d	0,5		1,5			0,75		1,5			1,5	
	d/d		0,6		1,5			0,9		1,5			2,0	
6 N/mm <sup>2</sup>	w/w	w/d	0,75		2,0			1,2		2,0			2,5	
	d/d		0,9		2,5			1,2		2,5			2,5	
8 N/mm <sup>2</sup>	w/w	w/d	0,9		3,0			1,5		3,0			3,5	
	d/d		1,2		3,0			2,0		3,0			3,5	

**Table C50.2:** Characteristic resistance under tension load (Push through anchorage)

Anchor rod	M10		M12		M16	
Perforated sleeve FIS H K	18x130/200				22x130/200	
<b><math>N_{Rk} = N_{Rk,p} = N_{Rk,b}</math> [kN] depending on the compressive strength <math>f_b</math> (temperature range 50/80°C)</b>						
compressive strength $f_b$	use category					
4 N/mm <sup>2</sup>	w/w	w/d	0,75		1,5	
	d/d		0,9		2,0	
6 N/mm <sup>2</sup>	w/w	w/d	1,2		2,5	
	d/d		1,2		2,5	
8 N/mm <sup>2</sup>	w/w	w/d	1,5		3,5	
	d/d		2,0		3,5	

Factor for job site tests and displacements see annex C110

Factor for temperature range 72/120°C: 0,83

fischer injection system FIS V Plus for masonry

**Performance**

Vertical perforated brick HLz, Characteristic resistance under tension load

**Annex C 50**

### Vertical perforated brick HLz, EN 771-1:2015

**Table C51.1:** Characteristic resistance under shear load (Pre-positioned anchorage)

Anchor rod	M6	M8	M6	M8	-	M8	M10	M8	M10	-	M12	M16	M12	M16	
Internal threaded anchor FIS E	-		-		M6	M8	-		-		M10	M12	-		
					11x85						15x85				
Perforated sleeve FIS H K	12x50		12x85		16x85			16x130		20x85			20x130		
<b><math>V_{Rk} = V_{Rk,b} = V_{Rk,c}</math> [kN] depending on the compressive strength <math>f_b</math> (temperature range 50/80°C and 72/120°C)</b>															
compressive strength $f_b$	use category														
4 N/mm <sup>2</sup>	w/w	w/d	1,5					0,9		1,5		2,5		0,9	
	d/d														
6 N/mm <sup>2</sup>	w/w	w/d	2,5					1,5		2,5		3,5		1,5	
	d/d														
8 N/mm <sup>2</sup>	w/w	w/d	3,5					2,0		3,5		4,5		2,0	
	d/d														

**Table C51.2:** Characteristic resistance under shear load (Push through anchorage)

Anchor rod	M10		M12		M16	
Perforated sleeve FIS H K	18x130/200				22x130/200	
<b><math>V_{Rk} = V_{Rk,b} = V_{Rk,c}</math> [kN] depending on the compressive strength <math>f_b</math> (temperature range 50/80°C and 72/120°C)</b>						
compressive strength $f_b$	use category					
4 N/mm <sup>2</sup>	w/w	w/d	0,9			
	d/d					
6 N/mm <sup>2</sup>	w/w	w/d	1,5			
	d/d					
8 N/mm <sup>2</sup>	w/w	w/d	2,0			
	d/d					

Factor for job site tests and displacements see annex C110

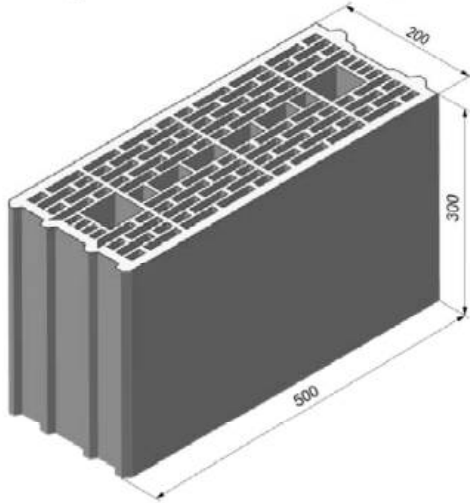
fischer injection system FIS V Plus for masonry

**Performance**

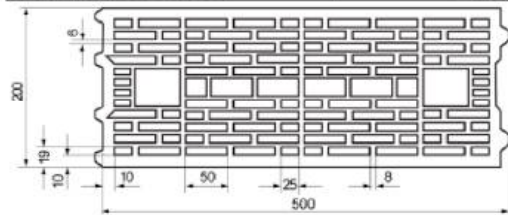
Vertical perforated brick HLz, Characteristic resistance under shear load

**Annex C 51**

**Vertical perforated brick HLz, EN 771-1:2015**



Vertical perforated brick HLz, EN 771-1:2015			
Producer	e.g. Wienerberger		
Nominal dimensions [mm]	length L	width W	height H
	500	200	300
Density $\rho$ [kg/dm <sup>3</sup> ]	≥ 0,7		
Compressive strength $f_b$ [N/mm <sup>2</sup> ]	4 / 6 / 8 / 10		
Standard or annex	EN 771-1:2015		



Dimension see also Annex B 17

**Table C52.1:** Installation parameters  
(Pre-positioned anchorage with perforated sleeve FIS H K)

<b>Anchor rod</b>	M6	M8	M6	M8	-	M8	M10	M8	M10	-	M12	M16	M12	M16
<b>Internal threaded anchor FIS E</b>	-	-	M6	M8	11x85	-	-	M10	M12	15x85	-	-	-	-
<b>Perforated sleeve FIS H K</b>	12x50	12x85	16x85	16x130	20x85	20x130								
<b>Anchor rod and internal threaded anchor FIS E with perforated sleeve FIS H K</b>														
Max. installation torque	$T_{inst}$ [Nm]	2												
<b>General installation parameters</b>														
Edge distance	$c_{min}$	50				80				50	80			
Spacing	$s_{min \parallel}$	100												
	$s_{cr \parallel}$	500												
	$s_{min \perp} = s_{cr \perp}$	300												
<b>Drilling method</b>														
Hammer drilling with hard metal hammer drill														

**Table C52.2:** Group factors

<b>Anchor rod</b>	M6	M8	M6	M8	-	M8	M10	M8	M10	-	M12	M16	M12	M16
<b>Internal threaded anchor FIS E</b>	-	-	M6	M8	11x85	-	-	M10	M12	15x85	-	-	-	-
<b>Perforated sleeve FIS H K</b>	12x50	12x85	16x85	16x130	20x85	20x130								
Group factors	$\alpha_{g,N \parallel}$	1,4												
	$\alpha_{g,v \parallel}$	2												
	$\alpha_{g,N \perp} = \alpha_{g,v \perp}$													

fischer injection system FIS V Plus for masonry

**Performance**  
Vertical perforated brick HLz, dimensions, installation parameters

**Annex C 52**



### Vertical perforated brick HLz, EN 771-1:2015

**Table C53.1:** Installation parameters  
(Push through anchorage with perforated sleeve FIS H K)

Anchor rod		M10	M12	M16
Perforated sleeve FIS H K		18x130/200		22x130/200
Anchor rod with perforated sleeve FIS H K				
Max. installation torque	$T_{inst}$	[Nm]	2	
<b>General installation parameters</b>				
Edge distance	$c_{min}$	[mm]	80	
Spacing	$s_{min \parallel}$		100	
	$s_{cr \parallel}$		500	
	$s_{min \perp} = s_{cr \perp}$		300	
<b>Drilling method</b>				
Hammer drilling with hard metal hammer drill				

**Table C53.2:** Group factors

Anchor rod		M10	M12	M16
Perforated sleeve FIS H K		18x130/200		22x130/200
Group factors	$\alpha_{g,N \parallel}$	[-]	1,4	
	$\alpha_{g,V \parallel}$		2	
	$\alpha_{g,N \perp} = \alpha_{g,V \perp}$			

fischer injection system FIS V Plus for masonry

**Performance**  
Vertical perforated brick HLz, dimensions, installation parameters

**Annex C 53**

### Vertical perforated brick HLz, EN 771-1:2015

**Table C54.1:** Characteristic resistance under tension load (Pre-positioned anchorage)

Anchor rod	M6	M8	M6	M8	-	M8	M10	M8	M10	-	M12	M16	M12	M16
Internal threaded anchor FIS E	-	-	M6 M8		M6 M8		-	-	M10 M12		-	-	-	-
Perforated sleeve FIS H K	12x50		12x85		16x85			16x130		20x85			20x130	
<b><math>N_{Rk} = N_{Rk,p} = N_{Rk,b}</math> [kN] depending on the compressive strength <math>f_b</math> (temperature range 50/80°C)</b>														
compressive strength $f_b$	use category													
4 N/mm <sup>2</sup>	w/w	w/d	0,5		0,6		1,2		0,75		1,5			
	d/d		0,6		0,75		1,2		0,9		1,5			
6 N/mm <sup>2</sup>	w/w	w/d	0,75		0,9		1,5		1,2		2,0			
	d/d		0,9		1,2		2,0		1,2		2,5			
8 N/mm <sup>2</sup>	w/w	w/d	0,9		1,2		2,0		1,5		2,5			
	d/d		1,2		1,5		2,5		1,5		3,0			
10 N/mm <sup>2</sup>	w/w	w/d	1,2		1,5		2,5		2,0		3,5			
	d/d		1,5		2,0		3,0		2,0		4,0			

**Table C54.2:** Characteristic resistance under tension load (Push through anchorage)

Anchor rod	M10	M12	M16
Perforated sleeve FIS H K	18x130/200		22x130/200
<b><math>N_{Rk} = N_{Rk,p} = N_{Rk,b}</math> [kN] depending on the compressive strength <math>f_b</math> (temperature range 50/80°C)</b>			
compressive strength $f_b$	use category		
4 N/mm <sup>2</sup>	w/w	w/d	1,2
	d/d		1,2
6 N/mm <sup>2</sup>	w/w	w/d	1,5
	d/d		2,0
8 N/mm <sup>2</sup>	w/w	w/d	2,0
	d/d		2,5
10 N/mm <sup>2</sup>	w/w	w/d	2,5
	d/d		3,0

Factor for job site tests and displacements see annex C110

Factor for temperature range 72/120°C: 0,83

fischer injection system FIS V Plus for masonry

**Performance**  
Vertical perforated brick HLz, Characteristic resistance under tension load

**Annex C 54**

### Vertical perforated brick HLz, EN 771-1:2015

**Table C55.1:** Characteristic resistance under shear load (Pre-positioned anchorage)

Anchor rod	M6	M8	M6	M8	-	M8	M10	M8	M10	-	M12	M16	M12	M16
Internal threaded anchor FIS E	-		-		M6	M8	-		-		M10	M12	-	
					11x85						15x85			
Perforated sleeve FIS H K	12x50		12x85		16x85			16x130		20x85			20x130	
<b><math>V_{Rk} = V_{Rk,b} = V_{Rk,c}</math> [kN] depending on the compressive strength <math>f_b</math> (temperature range 50/80°C and 72/120°C)</b>														
compressive strength $f_b$	use category													
	w/w	w/d												
4 N/mm <sup>2</sup>	d/d		0,9	1,2	0,9	1,2	0,6	2,0			0,6			
	w/w	w/d												
6 N/mm <sup>2</sup>	d/d		1,2	1,5	1,2	1,5	0,9	3,0			0,9			
	w/w	w/d												
8 N/mm <sup>2</sup>	d/d		1,5	2,0	1,5	2,0	1,2	4,0			1,2			
	w/w	w/d												
10 N/mm <sup>2</sup>	d/d		2,0	3,0	2,0	3,0	1,5	5,0			1,5			
	w/w	w/d												

**Table C55.2:** Characteristic resistance under shear load (Push through anchorage)

Anchor rod	M10		M12		M16	
Perforated sleeve FIS H K	18x130/200				22x130/200	
<b><math>V_{Rk} = V_{Rk,b} = V_{Rk,c}</math> [kN] depending on the compressive strength <math>f_b</math> (temperature range 50/80°C and 72/120°C)</b>						
compressive strength $f_b$	use category					
	w/w	w/d				
4 N/mm <sup>2</sup>	d/d		0,6			
	w/w	w/d				
6 N/mm <sup>2</sup>	d/d		0,9			
	w/w	w/d				
8 N/mm <sup>2</sup>	d/d		1,2			
	w/w	w/d				
10 N/mm <sup>2</sup>	d/d		1,5			
	w/w	w/d				

Factor for job site tests and displacements see annex C110

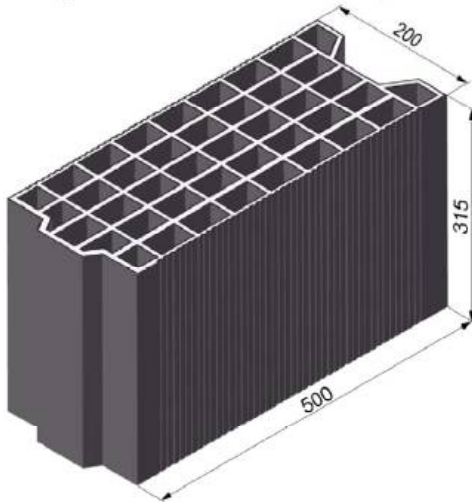
fischer injection system FIS V Plus for masonry

**Performance**

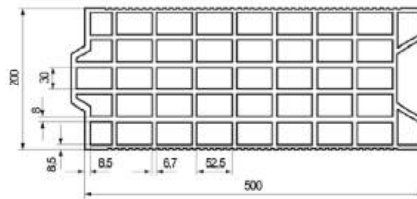
Vertical perforated brick HLz, Characteristic resistance under shear load

**Annex C 55**

**Vertical perforated brick HLz, EN 771-1:2015**



Vertical perforated brick HLz, EN 771-1:2015			
Producer	e.g. Terreal		
Nominal dimensions [mm]	length L	width W	height H
	500	200	315
Density $\rho$ [kg/dm <sup>3</sup> ]	≥ 0,7		
Compressive strength $f_b$ [N/mm <sup>2</sup> ]	2 / 4 / 6 / 8		
Standard or annex	EN 771-1:2015		



Dimension see also Annex B 17

**Table C56.1:** Installation parameters  
(Pre-positioned anchorage with perforated sleeve FIS H K)

<b>Anchor rod</b>	M6	M8	M6	M8	-	M8	M10	M8	M10	-	M12	M16	M12	M16
<b>Internal threaded anchor FIS E</b>	-	-	M6	M8	M6	M8	M10	M8	M10	M10	M12	-	-	-
<b>Perforated sleeve FIS H K</b>	12x50	12x85	12x85	12x85	16x85	16x85	16x130	16x130	16x130	20x85	20x85	20x85	20x130	20x130
<b>Anchor rod and internal threaded anchor FIS E with perforated sleeve FIS H K</b>														
Max. installation torque	$T_{inst}$	[Nm]	2											
<b>General installation parameters</b>														
Edge distance	$c_{min}$	[mm]	50				80				50		80	
Spacing	$s_{min II}$	[mm]	100											
	$s_{scr II}$		500											
	$s_{min \perp}$		100											
	$s_{scr \perp}$		315											
<b>Drilling method</b>														
Hammer drilling with hard metal hammer drill														

**Table C56.2:** Group factors

<b>Anchor rod</b>	M6	M8	M6	M8	-	M8	M10	M8	M10	-	M12	M16	M12	M16
<b>Internal threaded anchor FIS E</b>	-	-	M6	M8	M6	M8	M10	M8	M10	M10	M12	-	-	-
<b>Perforated sleeve FIS H K</b>	12x50	12x85	12x85	12x85	16x85	16x85	16x130	16x130	16x130	20x85	20x85	20x85	20x130	20x130
Group factors	$\alpha_{g,N II}$	[-]	1,1											
	$\alpha_{g,V II}$		1,2											
	$\alpha_{g,N \perp}$		1,1											
	$\alpha_{g,V \perp}$		1,2											

fischer injection system FIS V Plus for masonry

**Performance**  
Vertical perforated brick HLz, dimensions, installation parameters

**Annex C 56**

### Vertical perforated brick HLz, EN 771-1:2015

**Table C57.1:** Installation parameters  
(Push through anchorage with perforated sleeve FIS H K)

Anchor rod		M10	M12	M16
Perforated sleeve FIS H K		18x130/200		22x130/200
Anchor rod with perforated sleeve FIS H K				
Max. installation torque	$T_{inst}$ [Nm]	2		
<b>General installation parameters</b>				
Edge distance	$c_{min}$	80		
Spacing	$s_{min \parallel}$	100		
	$s_{cr \parallel}$ [mm]	500		
	$s_{min \perp}$	100		
	$s_{cr \perp}$	315		
<b>Drilling method</b>				
Hammer drilling with hard metal hammer drill				

**Table C57.2:** Group factors

Anchor rod		M10	M12	M16
Perforated sleeve FIS H K		18x130/200		22x130/200
Group factors	$\alpha_{g,N \parallel}$	1,1		
	$\alpha_{g,V \parallel}$	1,2		
	$\alpha_{g,N \perp}$	1,1		
	$\alpha_{g,V \perp}$	1,2		

fischer injection system FIS V Plus for masonry

**Performance**  
Vertical perforated brick HLz, dimensions, installation parameters

**Annex C 57**



### Vertical perforated brick HLz, EN 771-1:2015

**Table C58.1:** Characteristic resistance under tension load (Pre-positioned anchorage)

Anchor rod	M6	M8	M6	M8	-	M8	M10	M8	M10	-	M12	M16	M12	M16
Internal threaded anchor FIS E	-		-		M6	M8	-		-		M10	M12	-	
					11x85						15x85			
Perforated sleeve FIS H K	12x50		12x85		16x85			16x130		20x85			20x130	
<b><math>N_{Rk} = N_{Rk,p} = N_{Rk,b}</math> [kN] depending on the compressive strength <math>f_b</math> (temperature range 50/80°C)</b>														
compressive strength $f_b$	use category													
	w/w	w/d	0,5											
2 N/mm <sup>2</sup>	d/d		0,5				0,6		0,5			0,6		
	w/w	w/d	0,9											
4 N/mm <sup>2</sup>	d/d		0,9		1,2									
	w/w	w/d	1,5											
6 N/mm <sup>2</sup>	d/d		1,5											
	w/w	w/d	2,0											
8 N/mm <sup>2</sup>	d/d		2,0											

**Table C58.2:** Characteristic resistance under tension load (Push through anchorage)

Anchor rod	M10		M12		M16	
Perforated sleeve FIS H K	18x130/200				22x130/200	
<b><math>N_{Rk} = N_{Rk,p} = N_{Rk,b}</math> [kN] depending on the compressive strength <math>f_b</math> (temperature range 50/80°C)</b>						
compressive strength $f_b$	use category					
	w/w	w/d	0,5			
2 N/mm <sup>2</sup>	d/d		0,6			
	w/w	w/d	0,9			
4 N/mm <sup>2</sup>	d/d		1,2			
	w/w	w/d	1,5			
6 N/mm <sup>2</sup>	d/d		1,5			
	w/w	w/d	2,0			
8 N/mm <sup>2</sup>	d/d		2,0			

Factor for job site tests and displacements see annex C110

Factor for temperature range 72/120°C: 0,83

fischer injection system FIS V Plus for masonry

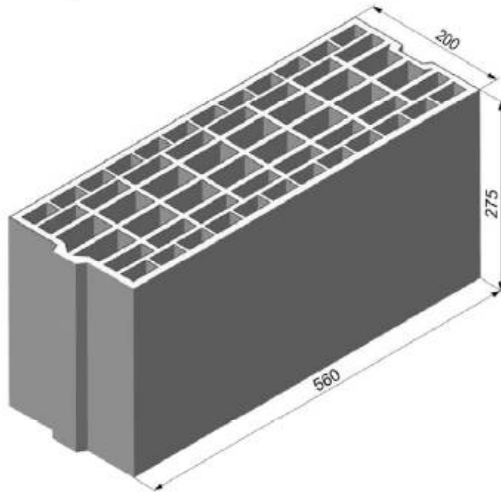
**Performance**

Vertical perforated brick HLz, Characteristic resistance under tension load

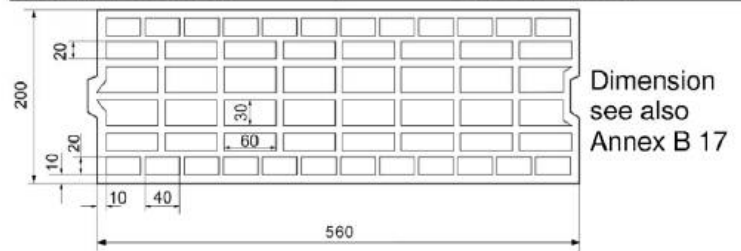
**Annex C 58**

<b>Vertical perforated brick HLz, EN 771-1:2015</b>																	
<b>Table C59.1: Characteristic resistance under shear load (Pre-positioned anchorage)</b>																	
Anchor rod		M6	M8	M6	M8	-		M8	M10	M8	M10	-		M12	M16	M12	M16
Internal threaded anchor FIS E		-		-		M6	M8	-		-		M10	M12	-		-	
				11x85								15x85					
Perforated sleeve FIS H K		12x50		12x85		16x85			16x130		20x85			20x130			
<b><math>V_{Rk} = V_{Rk,b} = V_{Rk,c}</math> [kN] depending on the compressive strength <math>f_b</math> (temperature range 50/80°C and 72/120°C)</b>																	
compressive strength $f_b$		use category															
2 N/mm <sup>2</sup>	w/w	w/d	0,3	0,6	0,3	0,6	0,6	0,6	0,9	0,75							
	d/d																
4 N/mm <sup>2</sup>	w/w	w/d	0,75	1,2	0,75	1,2	1,2	2,0	1,5	2,0							
	d/d																
6 N/mm <sup>2</sup>	w/w	w/d	0,9	2,0	0,9	2,0	1,5	3,0	2,0								
	d/d																
8 N/mm <sup>2</sup>	w/w	w/d	1,5	2,5	1,5	2,5	2,0	4,0	3,0								
	d/d																
<b>Table C59.2: Characteristic resistance under shear load (Push through anchorage)</b>																	
Anchor rod		M10				M12				M16							
Perforated sleeve FIS H K		18x130/200								22x130/200							
<b><math>V_{Rk} = V_{Rk,b} = V_{Rk,c}</math> [kN] depending on the compressive strength <math>f_b</math> (temperature range 50/80°C and 72/120°C)</b>																	
compressive strength $f_b$		use category															
2 N/mm <sup>2</sup>	w/w	w/d	0,6						0,75								
	d/d																
4 N/mm <sup>2</sup>	w/w	w/d	1,2						1,5								
	d/d																
6 N/mm <sup>2</sup>	w/w	w/d	1,5						2,0								
	d/d																
8 N/mm <sup>2</sup>	w/w	w/d	2,0						3,0								
	d/d																
Factor for job site tests and displacements see annex C110																	
fischer injection system FIS V Plus for masonry														<b>Annex C 59</b>			
<b>Performance</b> Vertical perforated brick HLz, Characteristic resistance under shear load																	

**Vertical perforated brick HLz, EN 771-1:2015**



Vertical perforated brick HLz, EN 771-1:2015			
Producer	e.g. Imery		
Nominal dimensions [mm]	length L	width W	height H
	560	200	275
Density $\rho$ [kg/dm <sup>3</sup> ]	≥ 0,7		
Compressive strength $f_b$ [N/mm <sup>2</sup> ]	4 / 6 / 8		
Standard or annex	EN 771-1:2015		



**Table C60.1: Installation parameters**

Anchor rod	M8	M10	M10	M12	M12	M16	M16
Perforated sleeve FIS H K	16x130		18x130/200		20x130		22x130/200
<b>Anchor rod with perforated sleeve FIS H K</b>							
Max. installation torque $T_{inst}$ [Nm]	2						
<b>General installation parameters</b>							
Edge distance $c_{min}$	80						
Spacing $s_{min}$ [mm]	$s_{min} \parallel = s_{cr} \parallel$	560					
	$s_{min} \perp = s_{cr} \perp$	275					
<b>Drilling method</b>							
Hammer drilling with hard metal hammer drill							

**Table C60.2: Group factors**

Anchor rod	M8	M10	M10	M12	M12	M16	M16
Perforated sleeve FIS H K	16x130		18x130/200		20x130		22x130/200
Group factors	$\alpha_{g,N} \parallel$	[-]	2				
	$\alpha_{g,v} \parallel$						
	$\alpha_{g,N} \perp$						
	$\alpha_{g,v} \perp$						

fischer injection system FIS V Plus for masonry

**Performance**  
Vertical perforated brick HLz, dimensions, installation parameters

**Annex C 60**

### Vertical perforated brick HLz, EN 771-1:2015

**Table C61.1:** Characteristic resistance under tension load

Anchor rod		M8	M10	M10	M12	M12	M16	M16
Perforated sleeve FIS H K		16x130		18x130/200		20x130		22x130/200
<b><math>N_{Rk} = N_{Rk,p} = N_{Rk,b}</math> [kN] depending on the compressive strength <math>f_b</math> (temperature range 50/80°C)</b>								
compressive strength $f_b$	use category							
	w/w	w/d						
4 N/mm <sup>2</sup>	w/w	w/d	0,9			1,2		
		d/d	1,2			1,5		
6 N/mm <sup>2</sup>	w/w	w/d	1,5			2,0		
		d/d	1,5			2,0		
8 N/mm <sup>2</sup>	w/w	w/d	2,0			2,5		
		d/d	2,5			3,0		

Factor for temperature range 72/120°C: 0,83

**Table C61.2:** Characteristic resistance under shear load

Anchor rod		M8	M10	M10	M12	M12	M16	M16
Perforated sleeve FIS H K		16x130		18x130/200		20x130		22x130/200
<b><math>V_{Rk} = V_{Rk,b} = V_{Rk,c}</math> [kN] depending on the compressive strength <math>f_b</math> (temperature range 50/80°C and 72/120°C)</b>								
compressive strength $f_b$	use category							
	w/w	w/d						
4 N/mm <sup>2</sup>	w/w	w/d				0,9		
		d/d				0,9		
6 N/mm <sup>2</sup>	w/w	w/d				1,5		
		d/d				1,5		
8 N/mm <sup>2</sup>	w/w	w/d				2,0		
		d/d				2,0		

Factor for job site tests and displacements see annex C110

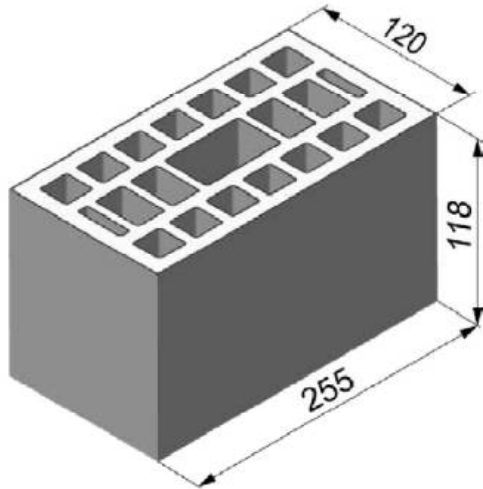
fischer injection system FIS V Plus for masonry

**Performance**

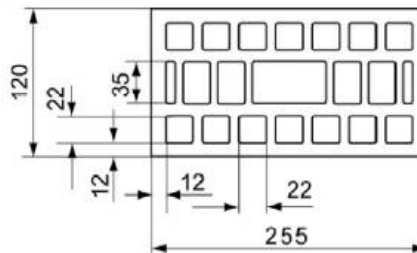
Vertical perforated brick HLz, Characteristic resistance under tension and shear load

**Annex C 61**

**Vertical perforated brick HLz, EN 771-1:2015**



Vertical perforated brick HLz, EN 771-1:2015			
Producer	e.g. Wienerberger		
Nominal dimensions [mm]	length L	width W	height H
	255	120	118
Density $\rho$ [kg/dm <sup>3</sup> ]	≥ 1,0		
Compressive strength $f_b$ [N/mm <sup>2</sup> ]	2 / 4 / 6 / 8 / 10 / 12		
Standard or annex	EN 771-1:2015		



**Table C62.1: Installation parameters**

<b>Anchor rod</b>	M6	M8	M6	M8	-	M8	M10	-	M12	M16
<b>Internal threaded anchor FIS E</b>	-		-		M6	M8	-		M10	M12
					11x85				15x85	
<b>Perforated sleeve FIS H K</b>	12x50		12x85		16x85			20x85		
<b>Anchor rod and internal threaded anchor FIS E with perforated sleeve FIS H K</b>										
Max. installation torque $T_{inst}$ [Nm]	2									
<b>General installation parameters</b>										
Edge distance $c_{min}$	60									
Spacing $s_{cr \parallel} = s_{min \parallel}$ [mm]	255									
	$s_{cr \perp} = s_{min \perp}$	120								
<b>Drilling method</b>										
Hammer drilling with hard metal hammer drill										

**Table C62.2: Group factors**

<b>Anchor rod</b>	M6	M8	M6	M8	-	M8	M10	-	M12	M16
<b>Internal threaded anchor FIS E</b>	-		-		M6	M8	-		M10	M12
					11x85				15x85	
<b>Perforated sleeve FIS H K</b>	12x50		12x85		16x85			20x85		
Group factors	$\alpha_{g,N \parallel}$	[-]	2							
	$\alpha_{g,v \parallel}$									
	$\alpha_{g,N \perp}$									
	$\alpha_{g,v \perp}$									

fischer injection system FIS V Plus for masonry

**Performance**  
Vertical perforated brick HLz, dimensions, installation parameters

**Annex C 62**



**Vertical perforated brick HLz, EN 771-1:2015**

**Table C63.1:** Characteristic resistance under tension load

Anchor rod		M6	M8	M6	M8	-		M8	M10	-		M12	M16
Internal threaded anchor FIS E		-		-		M6	M8	-		M10	M12	-	
						11x85				15x85			
Perforated sleeve FIS H K		12x50		12x85		16x85				20x85			
<b><math>N_{Rk} = N_{Rk,p} = N_{Rk,b}</math> [kN] depending on the compressive strength <math>f_b</math> (temperature range 50/80°C)</b>													
compressive strength $f_b$	use category												
2 N/mm <sup>2</sup>	w/w	w/d	0,4		0,5				- <sup>1)</sup>				
	d/d		0,5		0,5				- <sup>1)</sup>				
4 N/mm <sup>2</sup>	w/w	w/d	0,9		0,9				0,5				
	d/d		0,9		1,2				0,5				
6 N/mm <sup>2</sup>	w/w	w/d	1,2		1,5				0,75				
	d/d		1,5		1,5				0,75				
8 N/mm <sup>2</sup>	w/w	w/d	1,5		2,0				0,9				
	d/d		2,0		2,0				0,9				
10 N/mm <sup>2</sup>	w/w	w/d	2,0		2,5				1,2				
	d/d		2,5		2,5				1,2				
12 N/mm <sup>2</sup>	w/w	w/d	2,5		3,0				1,5				
	d/d		3,0		3,5				1,5				

<sup>1)</sup> No performance assesses

Factor for job site tests and displacements see annex C110

Factor for temperature range 72/120°C: 0,83

fischer injection system FIS V Plus for masonry

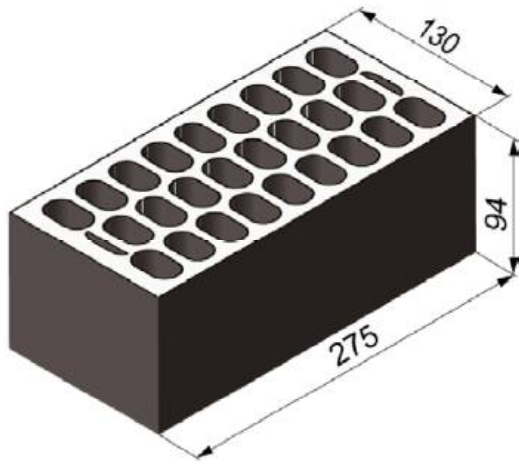
**Performance**

Vertical perforated brick HLz, Characteristic resistance under tension load

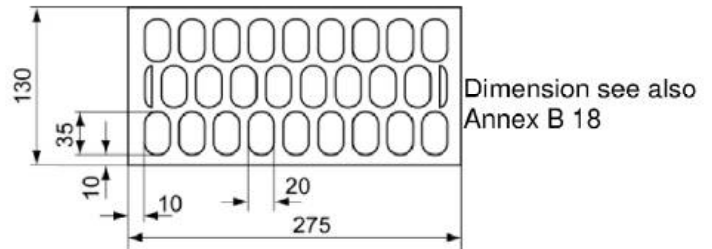
**Annex C 63**

<b>Vertical perforated brick HLz, EN 771-1:2015</b>										
<b>Table C64.1: Characteristic resistance under shear load</b>										
Anchor rod	M6	M8	M6	M8	-	M8	M10	-	M12	M16
Internal threaded anchor FIS E	-		-		M6	M8	-		M10	M12
					11x85				15x85	
Perforated sleeve FIS H K	12x50		12x85		16x85			20x85		
<b><math>V_{Rk} = V_{Rk,b} = V_{Rk,c}</math> [kN] depending on the compressive strength <math>f_b</math> (temperature range 50/80°C and 72/120°C)</b>										
compressive strength $f_b$	use category									
	w/w	w/d								
2 N/mm <sup>2</sup>	d/d	0,6	0,75	0,6	0,75	0,9				
	d/d	1,2	1,5	1,2	1,5	2,0				
4 N/mm <sup>2</sup>	w/w	w/d								
	d/d	2,0	2,0	2,0	2,0	2,5				
6 N/mm <sup>2</sup>	w/w	w/d								
	d/d	2,5	3,0	2,5	3,0	3,5				
8 N/mm <sup>2</sup>	w/w	w/d								
	d/d	3,0	3,5	3,0	3,5	4,5				
10 N/mm <sup>2</sup>	w/w	w/d								
	d/d	4,0	4,5	4,0	4,5	5,5				
12 N/mm <sup>2</sup>	w/w	w/d								
	d/d									
Factor for job site tests and displacements see annex C110										
fischer injection system FIS V Plus for masonry										<b>Annex C 64</b>
<b>Performance</b> Vertical perforated brick HLz, Characteristic resistance under shear load										

**Vertical perforated brick HLz, EN 771-1:2015**



Vertical perforated brick HLz, EN 771-1:2015			
Producer	e.g. Ceramica Farreny S.A.		
Nominal dimensions [mm]	length L	width W	height H
	275	130	94
Density $\rho$ [kg/dm <sup>3</sup> ]	≥ 0,8		
Compressive strength $f_b$ [N/mm <sup>2</sup> ]	6 / 8 / 12 / 16 / 20		
Standard or annex	EN 771-1:2015		



**Table C65.1: Installation parameters**

<b>Anchor rod</b>	M6	M8	M6	M8	-	M8	M10	-	M12	M16
<b>Internal threaded anchor FIS E</b>	-		-		M6	M8	-		M10	M12
					11x85				15x85	
<b>Perforated sleeve FIS H K</b>	12x50		12x85		16x85			20x85		
<b>Anchor rod and internal threaded anchor FIS E with perforated sleeve FIS H K</b>										
Max. installation torque $T_{inst}$ [Nm]	2									
<b>General installation parameters</b>										
Edge distance $c_{min}$	100					120				
Spacing $s_{cr}$ [mm]	$s_{cr \parallel} = s_{min \parallel}$					275				
	$s_{cr \perp} = s_{min \perp}$					95				
<b>Drilling method</b>										
Hammer drilling with hard metal hammer drill										

**Table C65.2: Group factors**

<b>Anchor rod</b>	M6	M8	M6	M8	-	M8	M10	-	M12	M16
<b>Internal threaded anchor FIS E</b>	-		-		M6	M8	-		M10	M12
					11x85				15x85	
<b>Perforated sleeve FIS H K</b>	12x50		12x85		16x85			20x85		
Group factors	$\alpha_{g,N \parallel}$	[-]	2							
	$\alpha_{g,V \parallel}$									
	$\alpha_{g,N \perp}$									
	$\alpha_{g,V \perp}$									

fischer injection system FIS V Plus for masonry

**Performance**  
Vertical perforated brick HLz, dimensions, installation parameters

**Annex C 65**

### Vertical perforated brick HLz, EN 771-1:2015

**Table C66.1:** Characteristic resistance under tension load

Anchor rod	M6	M8	M6	M8	-	M8	M10	-	M12	M16	
Internal threaded anchor FIS E	-		-		M6	M8	-		M10	M12	-
					11x85				15x85		
Perforated sleeve FIS H K	12x50		12x85		16x85			20x85			
<b><math>N_{Rk} = N_{Rk,p} = N_{Rk,b}</math> [kN] depending on the compressive strength <math>f_b</math> (temperature range 50/80°C)</b>											
compressive strength $f_b$	use category										
6 N/mm <sup>2</sup>	w/w	w/d	0,4		0,9						
	d/d		0,4		0,9						
8 N/mm <sup>2</sup>	w/w	w/d	0,5		1,2						
	d/d		0,6		1,2						
12 N/mm <sup>2</sup>	w/w	w/d	0,75		1,5						
	d/d		0,9		2,0						
16 N/mm <sup>2</sup>	w/w	w/d	0,9		2,0						
	d/d		1,2		2,5						
20 N/mm <sup>2</sup>	w/w	w/d	1,2		3,0						
	d/d		1,5		3,0						

Factor for temperature range 72/120°C: 0,83

**Table C66.2:** Characteristic resistance under shear load

Anchor rod	M6	M8	M6	M8	-	M8	M10	-	M12	M16	
Internal threaded anchor FIS E	-		-		M6	M8	-		M10	M12	-
					11x85				15x85		
Perforated sleeve FIS H K	12x50		12x85		16x85			20x85			
<b><math>V_{Rk} = V_{Rk,b} = V_{Rk,c}</math> [kN] depending on the compressive strength <math>f_b</math> (temperature range 50/80°C and 72/120°C)</b>											
compressive strength $f_b$	use category										
6 N/mm <sup>2</sup>	w/w	w/d	1,2		1,2						
	d/d										
8 N/mm <sup>2</sup>	w/w	w/d	1,5		1,5						
	d/d										
12 N/mm <sup>2</sup>	w/w	w/d	2,0		2,5						
	d/d										
16 N/mm <sup>2</sup>	w/w	w/d	3,0		3,0						
	d/d										
20 N/mm <sup>2</sup>	w/w	w/d	4,0		4,0						
	d/d										

Factor for job site tests and displacements see annex C110

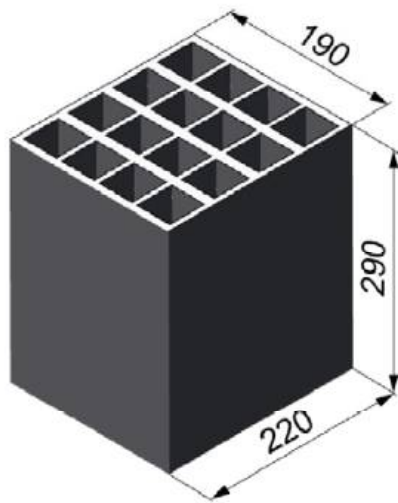
fischer injection system FIS V Plus for masonry

**Performance**

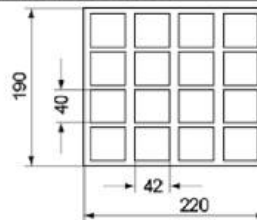
Vertical perforated brick HLz, Characteristic resistance under tension and shear load

**Annex C 66**

**Vertical perforated brick HLz, EN 771-1:2015**



Vertical perforated brick HLz, EN 771-1:2015			
Producer	e.g. Perceram		
Nominal dimensions [mm]	length L	width W	height H
	220	190	290
Density $\rho$ [kg/dm <sup>3</sup> ]	≥ 0,7		
Compressive strength $f_b$ [N/mm <sup>2</sup> ]	6 / 8 / 10		
Standard or annex	EN 771-1:2015		



Dimension see also Annex B 18

**Table C67.1:** Installation parameters  
(Pre-positioned anchorage with perforated sleeve FIS H K)

<b>Anchor rod</b>	M6	M8	M6	M8	-	M8	M10	M8	M10	-	M12	M16	M12	M16
<b>Internal threaded anchor FIS E</b>	-	-	M6	M8	11x85	-	-	M10	M12	15x85	-	-	-	-
<b>Perforated sleeve FIS H K</b>	12x50	12x85	16x85		16x130	20x85		20x130						
<b>Anchor rod and internal threaded anchor FIS E with perforated sleeve FIS H K</b>														
Max. installation torque	$T_{inst}$	[Nm]	2											
<b>General installation parameters</b>														
Edge distance	$C_{min}$	[mm]	110											
Spacing	$S_{min \parallel} = S_{cr \parallel}$	[mm]	220											
	$S_{min \perp} = S_{cr \perp}$	[mm]	290											
<b>Drilling method</b>														
Hammer drilling with hard metal hammer drill														

**Table C67.2:** Group factors

<b>Anchor rod</b>	M6	M8	M6	M8	-	M8	M10	M8	M10	-	M12	M16	M12	M16
<b>Internal threaded anchor FIS E</b>	-	-	M6	M8	11x85	-	-	M10	M12	15x85	-	-	-	-
<b>Perforated sleeve FIS H K</b>	12x50	12x85	16x85		16x130	20x85		20x130						
Group factors	$\alpha_{g,N \parallel}$	[-]	2											
	$\alpha_{g,v \parallel}$													
	$\alpha_{g,N \perp}$													
	$\alpha_{g,v \perp}$													

fischer injection system FIS V Plus for masonry

**Performance**  
Vertical perforated brick HLz, dimensions, installation parameters

**Annex C 67**



### Vertical perforated brick HLz, EN 771-1:2015

**Table C68.1:** Installation parameters  
(Push through anchorage with perforated sleeve FIS H K)

Anchor rod	M10	M12	M16
Perforated sleeve FIS H K	18x130/200		22x130/200
<b>Anchor rod with perforated sleeve FIS H K</b>			
Max. installation torque	$T_{inst}$ [Nm]	2	
<b>General installation parameters</b>			
Edge distance	$c_{min}$	110	
Spacing	$s_{min \parallel} = s_{cr \parallel}$ [mm]	220	
	$s_{min \perp} = s_{cr \perp}$	290	
<b>Drilling method</b>			
Hammer drilling with hard metal hammer drill			

**Table C68.2:** Group factors

Anchor rod	M10	M12	M16
Perforated sleeve FIS H K	18x130/200		22x130/200
Group factors	$\alpha_{g,N \parallel}$	2	
	$\alpha_{g,V \parallel}$		
	$\alpha_{g,N \perp}$		
	$\alpha_{g,V \perp}$		

fischer injection system FIS V Plus for masonry

**Performance**  
Vertical perforated brick HLz, dimensions, installation parameters

**Annex C 68**

### Vertical perforated brick HLz, EN 771-1:2015

**Table C69.1:** Characteristic resistance under tension load (Pre-positioned anchorage)

Anchor rod	M6	M8	M6	M8	-	M8	M10	M8	M10	-	M12	M16	M12	M16
Internal threaded anchor FIS E	-		-		M6	M8	-		-		M10	M12	-	
					11x85						15x85			
Perforated sleeve FIS H K	12x50		12x85		16x85			16x130		20x85			20x130	
<b><math>N_{Rk} = N_{Rk,p} = N_{Rk,b}</math> [kN] depending on the compressive strength <math>f_b</math> (temperature range 50/80°C)</b>														
compressive strength $f_b$	use category													
	w/w	w/d												
6 N/mm <sup>2</sup>	w/w	w/d	0,3	1,2	1,2		1,5		1,2		1,5			
	d/d		0,4	1,5	1,5		1,5		1,5		1,5			
8 N/mm <sup>2</sup>	w/w	w/d	0,5	1,5	1,5		2,0		1,5		2,0			
	d/d		0,5	2,0	2,0		2,5		2,0		2,5			
10 N/mm <sup>2</sup>	w/w	w/d	0,6	2,0	2,0		2,5		2,0		2,5			
	d/d		0,6	2,5	2,5		3,0		2,5		3,0			

**Table C69.2:** Characteristic resistance under tension load (Push through anchorage)

Anchor rod	M10		M12		M16	
Perforated sleeve FIS H K	18x130/200				22x130/200	
<b><math>N_{Rk} = N_{Rk,p} = N_{Rk,b}</math> [kN] depending on the compressive strength <math>f_b</math> (temperature range 50/80°C)</b>						
compressive strength $f_b$	use category					
	w/w	w/d				
6 N/mm <sup>2</sup>	w/w	w/d	1,5			
	d/d		1,5			
8 N/mm <sup>2</sup>	w/w	w/d	2,0			
	d/d		2,5			
10 N/mm <sup>2</sup>	w/w	w/d	2,5			
	d/d		3,0			

Factor for job site tests and displacements see annex C110

Factor for temperature range 72/120°C: 0,83

fischer injection system FIS V Plus for masonry

**Performance**

Vertical perforated brick HLz, Characteristic resistance under tension load

**Annex C 69**

### Vertical perforated brick HLz, EN 771-1:2015

**Table C70.1:** Characteristic resistance under shear load (Pre-positioned anchorage)

Anchor rod	M6	M8	M6	M8	-	M8	M10	M8	M10	-	M12	M16	M12	M16
Internal threaded anchor FIS E	-		-		M6	M8	-		-		M10	M12	-	
					11x85						15x85			
Perforated sleeve FIS H K	12x50		12x85		16x85			16x130		20x85			20x130	
<b><math>V_{Rk} = V_{Rk,b} = V_{Rk,c}</math> [kN] depending on the compressive strength <math>f_b</math> (temperature range 50/80°C and 72/120°C)</b>														
compressive strength $f_b$	use category													
	w/w	w/d												
6 N/mm <sup>2</sup>	w/w	w/d	1,5	1,5	1,5			2,5		1,5			2,0	
	d/d													
8 N/mm <sup>2</sup>	w/w	w/d	2,0	2,0	2,0			3,5		2,0			3,0	
	d/d													
10 N/mm <sup>2</sup>	w/w	w/d	2,5	3,0	3,0			4,5		3,0			3,5	
	d/d													

**Table C70.2:** Characteristic resistance under shear load (Push through anchorage)

Anchor rod	M10		M12		M16	
Perforated sleeve FIS H K	18x130/200				22x130/200	
<b><math>V_{Rk} = V_{Rk,b} = V_{Rk,c}</math> [kN] depending on the compressive strength <math>f_b</math> (temperature range 50/80°C and 72/120°C)</b>						
compressive strength $f_b$	use category					
	w/w	w/d				
6 N/mm <sup>2</sup>	w/w	w/d	2,0			
	d/d					
8 N/mm <sup>2</sup>	w/w	w/d	3,0			
	d/d					
10 N/mm <sup>2</sup>	w/w	w/d	3,5			
	d/d					

Factor for job site tests and displacements see annex C110

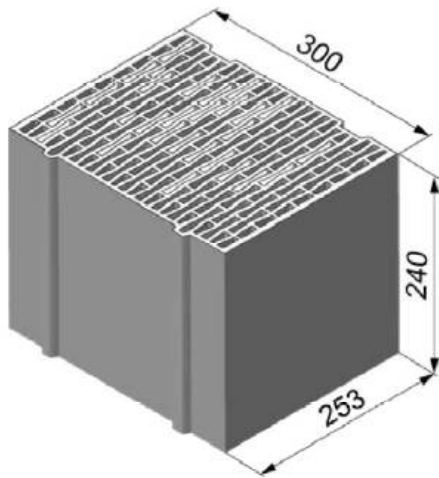
fischer injection system FIS V Plus for masonry

**Performance**

Vertical perforated brick HLz, Characteristic resistance under shear load

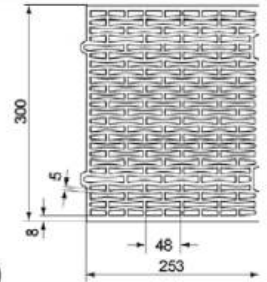
**Annex C 70**

**Vertical perforated brick HLz, EN 771-1:2015**



Vertical perforated brick HLz, EN 771-1:2015			
Producer	e.g. Ziegelwerk Brenna		
Nominal dimensions [mm]	length L	width W	height H
	253	300	240
Density $\rho$ [kg/dm <sup>3</sup> ]	≥ 0,8		
Compressive strength $f_b$ [N/mm <sup>2</sup> ]	2 / 4 / 6		
Standard or annex	EN 771-1:2015		

Dimension see also Annex B 18



**Table C71.1:** Installation parameters  
(Pre-positioned anchorage with perforated sleeve FIS H K)

<b>Anchor rod</b>	M6	M8	M6	M8	-	M8	M10	M8	M10	-	M12	M16	M12	M16
<b>Internal threaded anchor FIS E</b>	-	-	M6	M8	11x85	-	-	M10	M12	15x85	-	-	-	-
<b>Perforated sleeve FIS H K</b>	12x50	12x85	16x85		16x130		20x85		20x130					
<b>Anchor rod and internal threaded anchor FIS E with perforated sleeve FIS H K</b>														
Max. installation torque $T_{inst}$ [Nm]	2													
<b>General installation parameters</b>														
Edge distance $C_{min}$	60													
Spacing $S_{min}$	$S_{min} \parallel = S_{cr} \parallel$ [mm]													
	255													
	$S_{min} \perp = S_{cr} \perp$													
240														
<b>Drilling method</b>														
Hammer drilling with hard metal hammer drill														

**Table C71.2:** Group factors

<b>Anchor rod</b>	M6	M8	M6	M8	-	M8	M10	M8	M10	-	M12	M16	M12	M16
<b>Internal threaded anchor FIS E</b>	-	-	M6	M8	11x85	-	-	M10	M12	15x85	-	-	-	-
<b>Perforated sleeve FIS H K</b>	12x50	12x85	16x85		16x130		20x85		20x130					
Group factors	$\alpha_{g,N} \parallel$	[-]	2											
	$\alpha_{g,v} \parallel$													
	$\alpha_{g,N} \perp$													
	$\alpha_{g,v} \perp$													

fischer injection system FIS V Plus for masonry

**Performance**  
Vertical perforated brick HLz, dimensions, installation parameters

**Annex C 71**

<b>Vertical perforated brick HLz, EN 771-1:2015</b>			
<b>Table C72.1:</b> Installation parameters (Push through anchorage with perforated sleeve FIS H K)			
<b>Anchor rod</b>	<b>M10</b>	<b>M12</b>	<b>M16</b>
<b>Perforated sleeve FIS H K</b>	<b>18x130/200</b>		<b>22x130/200</b>
<b>Anchor rod with perforated sleeve FIS H K</b>			
Max. installation torque	$T_{inst}$ [Nm]	2	
<b>General installation parameters</b>			
Edge distance	$c_{min}$	60	
Spacing	$s_{min \parallel} = s_{cr \parallel}$ [mm]	255	
	$s_{min \perp} = s_{cr \perp}$	240	
<b>Drilling method</b>			
Hammer drilling with hard metal hammer drill			
<b>Table C72.2:</b> Group factors			
<b>Anchor rod</b>	<b>M10</b>	<b>M12</b>	<b>M16</b>
<b>Perforated sleeve FIS H K</b>	<b>18x130/200</b>		<b>22x130/200</b>
Group factors	$\alpha_{g,N \parallel}$	[-]	2
	$\alpha_{g,V \parallel}$		
	$\alpha_{g,N \perp}$		
	$\alpha_{g,V \perp}$		
fischer injection system FIS V Plus for masonry			<b>Annex C 72</b>
<b>Performance</b> Vertical perforated brick HLz, dimensions, installation parameters			



### Vertical perforated brick HLz, EN 771-1:2015

**Table C73.1:** Characteristic resistance under tension load (Pre-positioned anchorage)

Anchor rod	M6	M8	M6	M8	-	M8	M10	M8	M10	-	M12	M16	M12	M16
Internal threaded anchor FIS E	-		-		M6	M8	-		-		M10	M12	-	
					11x85						15x85			
Perforated sleeve FIS H K	12x50		12x85		16x85			16x130		20x85			20x130	
<b><math>N_{Rk} = N_{Rk,p} = N_{Rk,b}</math> [kN] depending on the compressive strength <math>f_b</math> (temperature range 50/80°C)</b>														
compressive strength $f_b$	use category													
2 N/mm <sup>2</sup>	w/w	w/d	- <sup>1)</sup>	0,5	0,5			0,4		0,5			0,4	
	d/d		0,3	0,5	0,5			0,5		0,5			0,5	
4 N/mm <sup>2</sup>	w/w	w/d	0,5	0,9	0,9			0,9		0,9			0,9	
	d/d		0,6	0,9	0,9			0,9		0,9			0,9	
6 N/mm <sup>2</sup>	w/w	w/d	0,75	1,5	1,5			1,2		1,5			1,2	
	d/d		0,9	1,5	1,5			1,5		1,5			1,5	

<sup>1)</sup> No performance assessed

**Table C73.2:** Characteristic resistance under tension load (Push through anchorage)

Anchor rod	M10		M12		M16	
Perforated sleeve FIS H K	18x130/200				22x130/200	
<b><math>N_{Rk} = N_{Rk,p} = N_{Rk,b}</math> [kN] depending on the compressive strength <math>f_b</math> (temperature range 50/80°C)</b>						
compressive strength $f_b$	use category					
2 N/mm <sup>2</sup>	w/w	w/d	0,4			
	d/d		0,5			
4 N/mm <sup>2</sup>	w/w	w/d	0,9			
	d/d		0,9			
6 N/mm <sup>2</sup>	w/w	w/d	1,2			
	d/d		1,5			

Factor for job site tests and displacements see annex C110

Factor for temperature range 72/120°C: 0,83

fischer injection system FIS V Plus for masonry

**Performance**

Vertical perforated brick HLz, Characteristic resistance under tension load

**Annex C 73**

### Vertical perforated brick HLz, EN 771-1:2015

**Table C74.1:** Characteristic resistance under shear load (Pre-positioned anchorage)

Anchor rod	M6	M8	M6	M8	-	M8	M10	M8	M10	-	M12	M16	M12	M16
Internal threaded anchor FIS E	-		-		M6	M8	-		-		M10	M12	-	
					11x85						15x85			
Perforated sleeve FIS H K	12x50		12x85		16x85			16x130		20x85			20x130	

$V_{Rk} = V_{Rk,b} = V_{Rk,c}$  [kN] depending on the compressive strength  $f_b$  (temperature range 50/80°C and 72/120°C)

compressive strength $f_b$	use category			
	w/w	w/d		
2 N/mm <sup>2</sup>	w/w	w/d	0,5	0,6
	d/d			
4 N/mm <sup>2</sup>	w/w	w/d	0,9	1,2
	d/d			
6 N/mm <sup>2</sup>	w/w	w/d	1,5	1,5
	d/d			

**Table C74.2:** Characteristic resistance under shear load (Push through anchorage)

Anchor rod	M10	M12	M16
Perforated sleeve FIS H K	18x130/200		22x130/200

$V_{Rk} = V_{Rk,b} = V_{Rk,c}$  [kN] depending on the compressive strength  $f_b$  (temperature range 50/80°C and 72/120°C)

compressive strength $f_b$	use category			
	w/w	w/d		
2 N/mm <sup>2</sup>	w/w	w/d	0,5	0,6
	d/d			
4 N/mm <sup>2</sup>	w/w	w/d	0,9	1,2
	d/d			
6 N/mm <sup>2</sup>	w/w	w/d	1,5	1,5
	d/d			

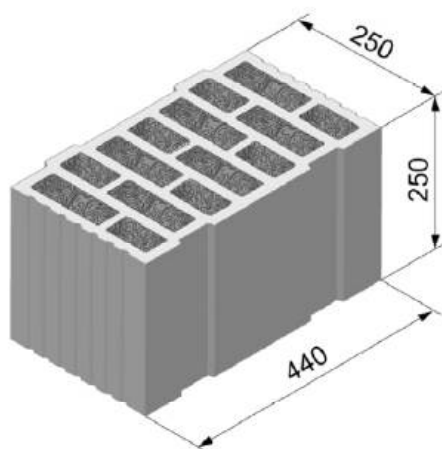
Factor for job site tests and displacements see annex C110

fischer injection system FIS V Plus for masonry

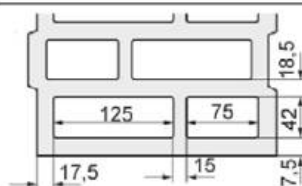
**Performance**  
Vertical perforated brick HLz, Characteristic resistance under shear load

**Annex C 74**

**Vertical perforated brick HLz, Porotherm W 44, filled with mineral wool, EN 771-1:2015**



Vertical perforated brick HLz, Porotherm W 44, filled with mineral wool, EN 771-1:2015			
Producer	-		
Nominal dimensions [mm]	length L	width W	height H
	250	440	250
Density $\rho$ [kg/dm <sup>3</sup> ]	0,7		
Compressive strength $f_b$ [N/mm <sup>2</sup> ]	6 / 8 / 10		
Standard or annex	EN 771-1:2015		



Dimension see also Annex B 18

**Table C75.1:** Installation parameters  
(Pre-positioned anchorage with perforated sleeve FIS H K)

Anchor rod		M6	M8	M6	M8	-	M8	M10	M8	M10	-	M12	M16	M12	M16	M12	M16
Internal threaded anchor FIS E		-	-	M6 M8			-	-	M10 M12			-	-	-	-	-	-
Perforated sleeve FIS H K		12x50		12x85		16x85		16x130		20x85		20x130		20x200			
Anchor rod and internal threaded anchor FIS E with perforated sleeve FIS H K																	
Max. installation torque	$T_{inst}$ [Nm]	2					5	2	5	6							
General installation parameters																	
Edge distance	$c_{min}$						60										
Spacing	$s_{min II}$						80										
	$s_{cr II}$ [mm]						250										
	$s_{min \perp}$						80										
	$s_{cr \perp}$						250										
Drilling method																	
Rotary drilling with carbide drill																	

**Table C75.2:** Group factors

Anchor rod		M6	M8	M6	M8	-	M8	M10	M8	M10	-	M12	M16	M12	M16	M12	M16
Internal threaded anchor FIS E		-	-	M6 M8			-	-	M10 M12			-	-	-	-	-	-
Perforated sleeve FIS H K		12x50		12x85		16x85		16x130		20x85		20x130		20x200			
Group factors	$\alpha_{g,N II}$						1,3										
	$\alpha_{g,V II}$						1,3										
	$\alpha_{g,N \perp}$						0,8										
	$\alpha_{g,V \perp}$						1,3										

fischer injection system FIS V Plus for masonry

**Performance**

Vertical perforated brick HLz, Porotherm W 44, filled with mineral wool;  
dimensions, installation parameters

**Annex C 75**

**Vertical perforated brick HLz, Porotherm W 44, filled with mineral wool, EN 771-1:2015**

**Table C76.1:** Installation parameters  
(Push through anchorage with perforated sleeve FIS H K)

Anchor rod		M10	M12	M16
Perforated sleeve FIS H K		18x130/200		22x130/200
Anchor rod with perforated sleeve FIS H K				
Max. installation torque	$T_{inst}$ [Nm]	5		6
<b>General installation parameters</b>				
Edge distance	$c_{min}$			60
	$s_{min \parallel}$			80
Spacing	$s_{cr \parallel}$ [mm]			250
	$s_{min \perp}$			80
	$s_{cr \perp}$			250
<b>Drilling method</b>				
Rotary drilling with carbide drill				

**Table C76.2:** Group factors

Anchor rod		M10	M12	M16
Perforated sleeve FIS H K		18x130/200		22x130/200
Group factors	$\alpha_{g,N \parallel}$			1,3
	$\alpha_{g,V \parallel}$			1,3
	$\alpha_{g,N \perp}$			0,8
	$\alpha_{g,V \perp}$			1,3

fischer injection system FIS V Plus for masonry

**Performance**

Vertical perforated brick HLz, Porotherm W 44, filled with mineral wool;  
dimensions, installation parameters

**Annex C 76**

**Vertical perforated brick HLz, Porotherm W 44, filled with mineral wool, EN 771-1:2015**

**Table C77.1:** Characteristic resistance under tension load (Pre-positioned anchorage)

Anchor rod	M6	M8	M6	M8	-	M8	M10	M8	M10	-	M12	M16	M12	M16	M12	M16
Internal threaded anchor FIS E	-	-			M6	M8				M10	M12					
					11x85					15x85						
Perforated sleeve FIS H K	12x50		12x85		16x85			16x130		20x85			20x130		20x200	
<b><math>N_{Rk} = N_{Rk,p} = N_{Rk,b}</math> [kN] depending on the compressive strength <math>f_b</math> (temperature range 50/80°C)</b>																
compressive strength $f_b$	use category															
6 N/mm <sup>2</sup>	w/w	w/d	0,75	1,5	1,2			1,5			2,5					
	d/d		0,9	1,5	1,2			1,5			2,5					
8 N/mm <sup>2</sup>	w/w	w/d	0,9	1,5	1,2			1,5			2,5					
	d/d		0,9	2,0	1,5			2,0			3,0					
10 N/mm <sup>2</sup>	w/w	w/d	0,9	2,0	1,5			2,0			3,0					
	d/d		1,2	2,0	1,5			2,0			3,5					

**Table C77.2:** Characteristic resistance under tension load (Push through anchorage)

Anchor rod	M10		M12		M16	
Perforated sleeve FIS H K	18x130/200				22x130/200	
<b><math>N_{Rk} = N_{Rk,p} = N_{Rk,b}</math> [kN] depending on the compressive strength <math>f_b</math> (temperature range 50/80°C)</b>						
compressive strength $f_b$	use category					
6 N/mm <sup>2</sup>	w/w	w/d	1,5			
	d/d		1,5			
8 N/mm <sup>2</sup>	w/w	w/d	1,5			
	d/d		2,0			
10 N/mm <sup>2</sup>	w/w	w/d	2,0			
	d/d		2,0			

Factor for job site tests and displacements see annex C110

Factor for temperature range 72/120°C: 0,83

fischer injection system FIS V Plus for masonry

**Performance**

Vertical perforated brick HLz, Porotherm W 44, filled with mineral wool,  
Characteristic resistance under tension load

**Annex C 77**



**Vertical perforated brick HLz, Porothersm W 44, filled with mineral wool, EN 771-1:2015**

**Table C78.1:** Characteristic resistance under shear load (Pre-positioned anchorage)

Anchor rod	M6	M8	M6	M8	-	M8	M10	M8	M10	-	M12	M16	M12	M16	M12	M16
Internal threaded anchor FIS E	-	-	-	-	M6	M8	-	-	M10	M12	-	-	-	-	-	-
					11x85				15x85							
Perforated sleeve FIS H K	12x50		12x85		16x85			16x130		20x85			20x130		20x200	

$V_{Rk} = V_{Rk,b} = V_{Rk,c}$  [kN] depending on the compressive strength  $f_b$  (temperature range 50/80°C and 72/120°C)

compressive strength $f_b$	use category							
	w/w	w/d						
6 N/mm <sup>2</sup>	w/w	w/d	0,9		1,2	0,9	1,2	1,2
	d/d							
8 N/mm <sup>2</sup>	w/w	w/d	0,9		1,5	0,9	1,5	1,2
	d/d							
10 N/mm <sup>2</sup>	w/w	w/d	1,2		1,5	1,2	1,5	1,5
	d/d							

**Table C78.2:** Characteristic resistance under shear load (Push through anchorage)

Anchor rod	M10	M12	M16
Perforated sleeve FIS H K	18x130/200		22x130/200

$V_{Rk} = V_{Rk,b} = V_{Rk,c}$  [kN] depending on the compressive strength  $f_b$  (temperature range 50/80°C and 72/120°C)

compressive strength $f_b$	use category			
	w/w	w/d		
6 N/mm <sup>2</sup>	w/w	w/d	1,2	
	d/d			
8 N/mm <sup>2</sup>	w/w	w/d	1,5	
	d/d			
10 N/mm <sup>2</sup>	w/w	w/d	1,5	
	d/d			

Factor for job site tests and displacements see annex C110

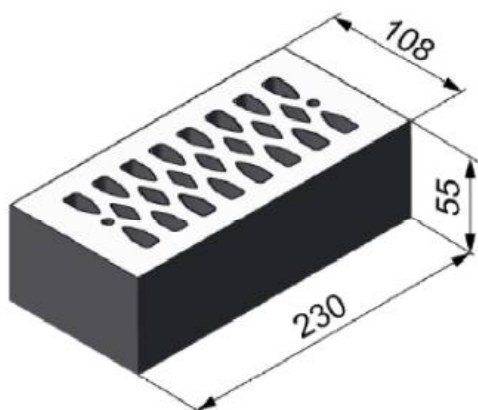
fischer injection system FIS V Plus for masonry

**Performance**

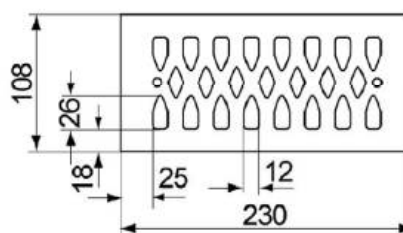
Vertical perforated brick HLz, Porothersm W 44, filled with mineral wool;  
Characteristic resistance under shear load

**Annex C 78**

### Vertical perforated brick HLz, EN 771-1:2015



Vertical perforated brick HLz, EN 771-1:2015			
Producer	e.g. Wienerberger.		
Nominal dimensions [mm]	length L	width W	height H
	230	108	55
Density $\rho$ [kg/dm <sup>3</sup> ]	≥ 1,4		
Compressive strength $f_b$ [N/mm <sup>2</sup> ]	2 / 4 / 6 / 8		
Standard or annex	EN 771-1:2015		



Dimension see also Annex B 18

**Table C79.1:** Installation parameters

<b>Anchor rod</b>	M6	M8	M6	M8	-	M8	M10	-	M12	M16
<b>Internal threaded anchor FIS E</b>	-		-		M6	M8	-		M10	M12
	-		-		11x85		-		15x85	
<b>Perforated sleeve FIS H K</b>	12x50		12x85		16x85			20x85		
<b>Anchor rod and internal threaded anchor FIS E with perforated sleeve FIS H K</b>										
Max. installation torque	$T_{inst}$	[Nm]	2							
<b>General installation parameters</b>										
Edge distance	$c_{min}$		60							
Spacing	$s_{min \parallel}$	[mm]	80							
	$s_{scr \parallel}$		230							
	$s_{min \perp}$		60							
	$s_{scr \perp}$		60							
<b>Drilling method</b>										
Hammer drilling with hard metal hammer drill										

**Table C79.2:** Group factors

<b>Anchor rod</b>	M6	M8	M6	M8	-	M8	M10	-	M12	M16
<b>Internal threaded anchor FIS E</b>	-		-		M6	M8	-		M10	M12
	-		-		11x85		-		15x85	
<b>Perforated sleeve FIS H K</b>	12x50		12x85		16x85			20x85		
Group factors	$\alpha_{g,N \parallel}$	[-]	2							
	$\alpha_{g,V \parallel}$		2							
	$\alpha_{g,N \perp}$		2							
	$\alpha_{g,V \perp}$		2							

fischer injection system FIS V Plus for masonry

**Performance**  
Vertical perforated brick HLz, dimensions, installation parameters

**Annex C 79**

### Vertical perforated brick HLz, EN 771-1:2015

**Table C80.1:** Characteristic resistance under tension load <sup>1)</sup>

Anchor rod		M6	M8	M6	M8	-	M8	M10	-	M12	M16
Internal threaded anchor FIS E		-	-			M6	M8	-	M10	M12	-
						11x85			15x85		
Perforated sleeve FIS H K		12x50		12x85		16x85			20x85		
<b><math>N_{Rk} = N_{Rk,p} = N_{Rk,b}</math> [kN] depending on the compressive strength <math>f_b</math> (temperature range 50/80°C)</b>											
compressive strength $f_b$		use category									
2 N/mm <sup>2</sup>	w/w	w/d	0,3	0,9	0,75			0,5			
		d/d	0,3	0,9	0,9			0,6			
4 N/mm <sup>2</sup>	w/w	w/d	0,6	1,5	1,5			0,9			
		d/d	0,75	2,0	1,5			1,2			
6 N/mm <sup>2</sup>	w/w	w/d	0,9	2,5	2,5			1,5			
		d/d	0,9	3,0	2,5			1,5			
8 N/mm <sup>2</sup>	w/w	w/d	1,2	3,5	3,0			2,0			
		d/d	1,5	4,0	3,5			2,5			

<sup>1)</sup> If the fixing is in a solid area, for w/w, the characteristic value shall be reduced with the factor 0,64.

Factor for temperature range 72/120°C: 0,83

**Table C80.2:** Characteristic resistance under shear load

Anchor rod		M6	M8	M6	M8	-	M8	M10	-	M12	M16
Internal threaded anchor FIS E		-	-			M6	M8	-	M10	M12	-
						11x85			15x85		
Perforated sleeve FIS H K		12x50		12x85		16x85			20x85		
<b><math>V_{Rk} = V_{Rk,b} = V_{Rk,c}</math> [kN] depending on the compressive strength <math>f_b</math> (temperature range 50/80°C and 72/120°C)</b>											
compressive strength $f_b$		use category									
2 N/mm <sup>2</sup>	w/w	w/d	0,6			0,4					
		d/d									
4 N/mm <sup>2</sup>	w/w	w/d	1,2			0,9					
		d/d									
6 N/mm <sup>2</sup>	w/w	w/d	1,5			1,2					
		d/d									
8 N/mm <sup>2</sup>	w/w	w/d	2,5			1,5					
		d/d									

Factor for job site tests and displacements see annex C110

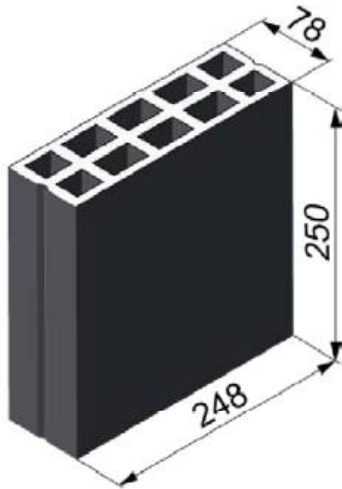
fischer injection system FIS V Plus for masonry

**Performance**

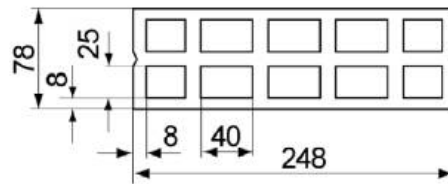
Vertical perforated brick HLz, Characteristic resistance under tension and shear load

**Annex C 80**

### Horizontal perforated brick LLz, EN 771-1:2015



Horizontal perforated brick LLz, EN 771-1:2015			
Producer	-		
Nominal dimensions [mm]	length L	width W	height H
	250	78	248
Density $\rho$ [kg/dm <sup>3</sup> ]	≥ 0,7		
Compressive strength $f_b$ [N/mm <sup>2</sup> ]	2 / 4 / 6		
Standard or annex	EN 771-1:2015		



Dimension see also Annex B 19

**Table C81.1:** Installation parameters

Anchor rod		M6	M8
Perforated sleeve FIS H K		12x50	
Anchor rod with perforated sleeve FIS H K			
Max. installation torque	$T_{inst}$ [Nm]	2	
<b>General installation parameters</b>			
Edge distance	$c_{min}$	100	
Spacing	$s_{min \parallel}$	75	
	$s_{cr \parallel}$	250	
	$s_{min \perp} = s_{cr \perp}$	250	
<b>Drilling method</b>			
Hammer drilling with hard metal hammer drill			

**Table C81.2:** Group factors

Anchor rod		M6	M8
Perforated sleeve FIS H K		12x50	
Group factors	$\alpha_{g,N \parallel}$	1,6	
	$\alpha_{g,V \parallel}$	1,1	
	$\alpha_{g,N \perp}$	2,0	
	$\alpha_{g,V \perp}$		

fischer injection system FIS V Plus for masonry

**Performance**  
Horizontal perforated brick LLz, dimensions, installation parameters

**Annex C 81**

### Horizontal perforated brick LLz, EN 771-1:2015

**Table C82.1:** Characteristic resistance under tension load

Anchor rod		M6	M8
Perforated sleeve FIS H K		12x50	
<b><math>N_{Rk} = N_{Rk,p} = N_{Rk,b}</math> [kN] depending on the compressive strength <math>f_b</math> (temperature range 50/80°C)</b>			
compressive strength $f_b$	use category		
	w/w	w/d	
2 N/mm <sup>2</sup>	w/w	w/d	0,5
	d/d		0,6
4 N/mm <sup>2</sup>	w/w	w/d	0,9
	d/d		1,2
6 N/mm <sup>2</sup>	w/w	w/d	1,5
	d/d		1,5

Factor for temperature range 72/120°C: 0,83

**Table C82.2:** Characteristic resistance under shear load

Anchor rod		M6	M8
Perforated sleeve FIS H K		12x50	
<b><math>V_{Rk} = V_{Rk,b} = V_{Rk,c}</math> [kN] depending on the compressive strength <math>f_b</math> (temperature range 50/80°C and 72/120°C)</b>			
compressive strength $f_b$	use category		
	w/w	w/d	
2 N/mm <sup>2</sup>	w/w	w/d	0,5
	d/d		
4 N/mm <sup>2</sup>	w/w	w/d	0,9
	d/d		
6 N/mm <sup>2</sup>	w/w	w/d	1,5
	d/d		

Factor for job site tests and displacements see annex C110

fischer injection system FIS V Plus for masonry

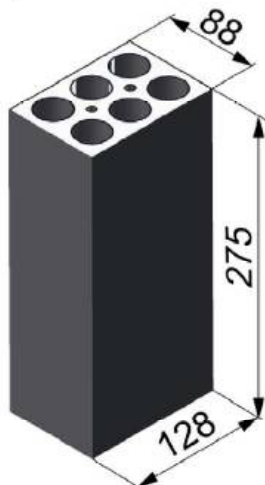
**Performance**

Horizontal perforated brick LLz, Characteristic resistance under tension and shear load

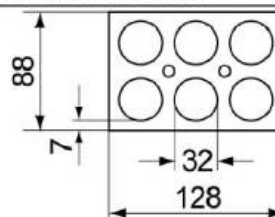
**Annex C 82**



### Horizontal perforated brick LLz, EN 771-1:2015



Horizontal perforated brick LLz, EN 771-1:2015			
Producer	e.g. Ceramica Farreny S.A.		
Nominal dimensions [mm]	length L	width W	height H
	275	88	128
Density $\rho$ [kg/dm <sup>3</sup> ]	≥ 0,8		
Compressive strength $f_b$ [N/mm <sup>2</sup> ]	2		
Standard or annex	EN 771-1:2015		



Dimension see also  
Annex B 19

**Table C83.1:** Installation parameters

Anchor rod		M6	M8
Perforated sleeve FIS H K		12x50	
Anchor rod with perforated sleeve FIS H K			
Max. installation torque	$T_{inst}$ [Nm]	2	
General installation parameters			
Edge distance	$c_{min}$	60	
Spacing	$s_{min \parallel}$	75	
	$s_{scr \parallel}$ [mm]	275	
	$s_{min \perp}$	75	
	$s_{scr \perp}$	130	
Drilling method			
Hammer drilling with hard metal hammer drill			

**Table C83.2:** Group factors

Anchor rod		M6	M8
Perforated sleeve FIS H K		12x50	
Group factors	$\alpha_{g,N \parallel}$	1,3	
	$\alpha_{g,V \parallel}$	1,5	
	$\alpha_{g,N \perp}$	1,3	
	$\alpha_{g,V \perp}$	1,5	

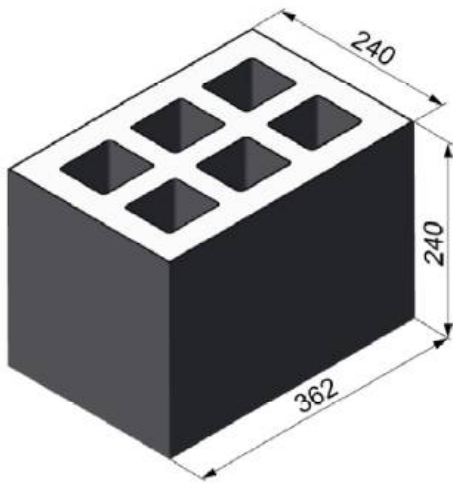
fischer injection system FIS V Plus for masonry

**Performance**  
Horizontal perforated brick LLz, dimensions, installation parameters

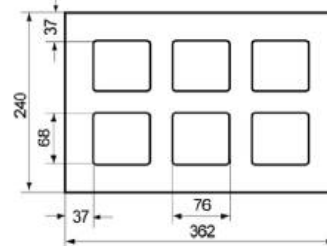
**Annex C 83**

<b>Horizontal perforated brick LLz, EN 771-1:2015</b>			
<b>Table C84.1: Characteristic resistance under tension load</b>			
<b>Anchor rod</b>		<b>M6</b>	<b>M8</b>
<b>Perforated sleeve FIS H K</b>		<b>12x50</b>	
<b><math>N_{Rk} = N_{Rk,p} = N_{Rk,b}</math> [kN] depending on the compressive strength <math>f_b</math> (temperature range 50/80°C)</b>			
compressive strength $f_b$	use category		1,5
	w/w	w/d	
<b>2 N/mm<sup>2</sup></b>	d/d		
	Factor for temperature range 72/120°C: 0,83		
<b>Table C84.2: Characteristic resistance under shear load</b>			
<b>Anchor rod</b>		<b>M6</b>	<b>M8</b>
<b>Perforated sleeve FIS H K</b>		<b>12x50</b>	
<b><math>V_{Rk} = V_{Rk,b} = V_{Rk,c}</math> [kN] depending on the compressive strength <math>f_b</math> (temperature range 50/80°C and 72/120°C)</b>			
compressive strength $f_b$	use category		1,2
	w/w	w/d	
<b>2 N/mm<sup>2</sup></b>	d/d		
	Factor for job site tests and displacements see annex C110		
fischer injection system FIS V Plus for masonry			<b>Annex C 84</b>
<b>Performance</b> Horizontal perforated brick LLz, Characteristic resistance under tension and shear load			

**Light-weight concrete hollow block Hbl, EN 771-3:2015**



Light-weight concrete hollow block Hbl, EN 771-3:2015			
Producer	-		
Nominal dimensions [mm]	Länge L	Breite B	Höhe H
	362	240	240
Density $\rho$ [kg/dm <sup>3</sup> ]	≥ 1,0		
Compressive strength $f_b$ [N/mm <sup>2</sup> ]	2 / 4		
Standard or annex	EN 771-3:2015		



Dimension see also Annex B 19

**Table C85.1:** Installation parameters  
(Pre-positioned anchorage with perforated sleeve FIS H K)

<b>Anchor rod</b>	M6	M8	M6	M8	-	M8	M10	M8	M10	-	M12	M16	M12	M16	M12	M16
<b>Internal threaded anchor FIS E</b>	-	-	-	-	M6	M8	-	-	-	M10	M12	-	-	-	-	-
					11x85					15x85						
<b>Perforated sleeve FIS H K</b>	12x50		12x85		16x85			16x130			20x85		20x130		20x200	
<b>Anchor rod and internal threaded anchor FIS E with perforated sleeve FIS H K</b>																
Max. installation torque	$T_{inst}$	[Nm]	2													
<b>General installation parameters</b>																
Edge distance	$C_{min}$	[mm]	60													
Spacing	$S_{min \parallel}$	[mm]	100													
	$S_{cr \parallel}$	[mm]	362													
	$S_{min \perp} = S_{cr \perp}$	[mm]	240													
<b>Drilling method</b>																
Hammer drilling with hard metal hammer drill																

**Table C85.2:** Group factors

<b>Anchor rod</b>	M6	M8	M6	M8	-	M8	M10	M8	M10	-	M12	M16	M12	M16	M12	M16
<b>Internal threaded anchor FIS E</b>	-	-	-	-	M6	M8	-	-	-	M10	M12	-	-	-	-	-
					11x85					15x85						
<b>Perforated sleeve FIS H K</b>	12x50		12x85		16x85			16x130			20x85		20x130		20x200	
Group factors	$\alpha_{g,N \parallel}$	[-]	1,2													
	$\alpha_{g,V \parallel}$		1,1													
	$\alpha_{g,N \perp}$		2,0													
	$\alpha_{g,V \perp}$		2,0													

fischer injection system FIS V Plus for masonry

**Performance**  
Light-weight concrete hollow block Hbl, dimensions, installation parameters

**Annex C 85**

**Light-weight concrete hollow block Hbl, EN 771-3:2015**

**Table C86.1:** Installation parameters  
(Push through anchorage with perforated sleeve FIS H K)

Anchor rod		M10	M12	M16
Perforated sleeve FIS H K		18x130/200		22x130/200
Anchor rod with perforated sleeve FIS H K				
Max. installation torque	$T_{inst}$	[Nm]	2	
<b>General installation parameters</b>				
Edge distance	$c_{min}$		60	
Spacing	$s_{min \parallel}$	[mm]	100	
	$s_{cr \parallel}$		362	
	$s_{min \perp} = s_{cr \perp}$		240	
<b>Drilling method</b>				
Hammer drilling with hard metal hammer drill				

**Table C86.2:** Group factors

Anchor rod		M10	M12	M16
Perforated sleeve FIS H K		18x130/200		22x130/200
Group factors	$\alpha_{g,N \parallel}$	[-]	1,2	
	$\alpha_{g,V \parallel}$		1,1	
	$\alpha_{g,N \perp}$		2,0	
	$\alpha_{g,V \perp}$			

fischer injection system FIS V Plus for masonry

**Performance**  
Light-weight concrete hollow block Hbl, dimensions, installation parameters

**Annex C 86**

### Light-weight concrete hollow block Hbl, EN 771-3:2015

**Table C87.1:** Characteristic resistance under tension load (Pre-positioned anchorage)

Anchor rod	M6	M8	M6	M8	-	M8	M10	M8	M10	-	M12	M16	M12	M16	M12	M16	
Internal threaded anchor FIS E	-	-			M6	M8				M10	M12						
					11x85					15x85							
Perforated sleeve FIS H K	12x50		12x85		16x85			16x130		20x85			20x130		20x200		
<b><math>N_{Rk} = N_{Rk,p} = N_{Rk,b}</math> [kN] depending on the compressive strength <math>f_b</math> (temperature range 50/80°C)</b>																	
compressive strength $f_b$	use category																
2 N/mm <sup>2</sup>	w/w	w/d	1,2								1,5						2,5
	d/d		1,2								1,5						2,5
4 N/mm <sup>2</sup>	w/w	w/d	2,0								3,0						5,0
	d/d		2,5								3,0						5,5

**Table C87.2:** Characteristic resistance under tension load (Push through anchorage)

Anchor rod	M10		M12		M16		
Perforated sleeve FIS H K	18x130/200				22x130/200		
<b><math>N_{Rk} = N_{Rk,p} = N_{Rk,b}</math> [kN] depending on the compressive strength <math>f_b</math> (temperature range 50/80°C)</b>							
compressive strength $f_b$	use category						
2 N/mm <sup>2</sup>	w/w	w/d					1,5
	d/d						1,5
4 N/mm <sup>2</sup>	w/w	w/d					3,0
	d/d						3,0

Factor for job site tests and displacements see annex C110

Factor for temperature range 72/120°C: 0,83

fischer injection system FIS V Plus for masonry

**Performance**

Light-weight concrete hollow block Hbl, Characteristic resistance under tension load

**Annex C 87**



**Light-weight concrete hollow block Hbl, EN 771-3:2015**

**Table C88.1:** Characteristic resistance under shear load (Pre-positioned anchorage)

Anchor rod	M6	M8	M6	M8	-	M8	M10	M8	M10	-	M12	M16	M12	M16	M12	M16
Internal threaded anchor FIS E	-	-	-	-	M6	M8	-	-	-	M10	M12	-	-	-	-	-
					11x85					15x85						
Perforated sleeve FIS H K	12x50		12x85		16x85			16x130		20x85			20x130		20x200	

$V_{Rk} = V_{Rk,b} = V_{Rk,c}$  [kN] depending on the compressive strength  $f_b$  (temperature range 50/80°C and 72/120°C)

compressive strength $f_b$	use category		
2 N/mm <sup>2</sup>	w/w	w/d	0,9
	d/d		
4 N/mm <sup>2</sup>	w/w	w/d	2,0
	d/d		

**Table C88.2:** Characteristic resistance under shear load (Push through anchorage)

Anchor rod	M10	M12	M16
Perforated sleeve FIS H K	18x130/200		22x130/200

$V_{Rk} = V_{Rk,b} = V_{Rk,c}$  [kN] depending on the compressive strength  $f_b$  (temperature range 50/80°C and 72/120°C)

compressive strength $f_b$	use category		
2 N/mm <sup>2</sup>	w/w	w/d	0,9
	d/d		
4 N/mm <sup>2</sup>	w/w	w/d	2,0
	d/d		

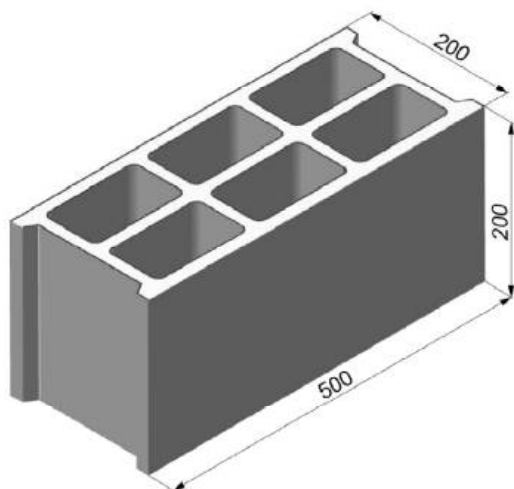
Factor for job site tests and displacements see annex C110

fischer injection system FIS V Plus for masonry

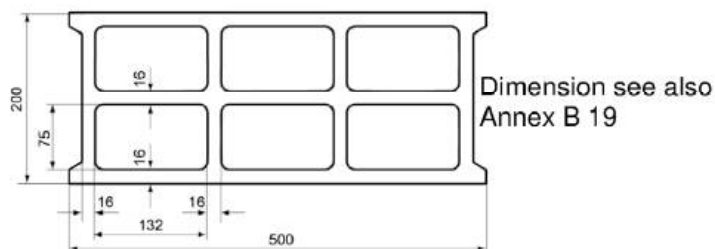
**Performance**  
Light-weight concrete hollow block Hbl, Characteristic resistance under shear load

**Annex C 88**

**Light-weight concrete hollow block Hbl, EN 771-3:2015**



Light-weight concrete hollow block Hbl, EN 771-3:2015			
Producer	e.g. Sepa		
Nominal dimensions [mm]	length L	width W	height H
	500	200	200
Density $\rho$ [kg/dm <sup>3</sup> ]	≥ 1,0		
Compressive strength $f_b$ [N/mm <sup>2</sup> ]	2 / 4 / 6		
Standard or annex	EN 771-1:2015		



**Table C89.1: Installation parameters**

<b>Anchor rod</b>	M6	M8	M6	M8	-	M8	M10	M8	M10	M10	M12	-	M12	M16
<b>Internal threaded anchor FIS E</b>	-	-	M6	M8	11x85	-	-	-	-	-	-	M10	M12	-
<b>Perforated sleeve FIS H K</b>	12x50	12x85	16x85		16x130	18x130/200		20x85						
<b>Anchor rod and internal threaded anchor FIS E with perforated sleeve FIS H K</b>														
Max. installation torque $T_{inst}$ [Nm]	1				2									
<b>General installation parameters</b>														
Edge distance $c_{min}$					100									
Spacing	$S_{min \parallel} = S_{scr \parallel}$ [mm]				500									
	$S_{min \perp} = S_{scr \perp}$				200									
<b>Drilling method</b>														
Hammer drilling with hard metal hammer drill														

**Table C89.2: Group factors**

<b>Anchor rod</b>	M6	M8	M6	M8	-	M8	M10	M8	M10	M10	M12	-	M12	M16
<b>Internal threaded anchor FIS E</b>	-	-	M6	M8	11x85	-	-	-	-	-	-	M10	M12	-
<b>Perforated sleeve FIS H K</b>	12x50	12x85	16x85		16x130	18x130/200		20x85						
Group factors	$\alpha_{g,N \parallel}$				2									
	$\alpha_{g,v \parallel}$													
	$\alpha_{g,N \perp}$													
	$\alpha_{g,v \perp}$													

fischer injection system FIS V Plus for masonry

**Performance**  
Light-weight concrete hollow block Hbl, dimensions, installation parameters

**Annex C 89**

### Light-weight concrete hollow block Hbl, EN 771-3:2015

**Table C90.1:** Characteristic resistance under tension load

Anchor rod	M6	M8	M6	M8	-	M8	M10	M8	M10	M10	M12	-	M12	M16	
Internal threaded anchor FIS E	-		-		M6	M8	-		-		-		M10	M12	-
					11x85								15x85		
Perforated sleeve FIS H K	12x50		12x85		16x85			16x130		18x130/200		20x85			

$N_{Rk} = N_{Rk,p} = N_{Rk,b}$  [kN] depending on the compressive strength  $f_b$  (temperature range 50/80°C)

compressive strength $f_b$	use category		
	w/w	w/d	
2 N/mm <sup>2</sup>	w/w	w/d	0,4
	d/d		0,5
4 N/mm <sup>2</sup>	w/w	w/d	0,9
	d/d		0,9
6 N/mm <sup>2</sup>	w/w	w/d	1,2
	d/d		1,5

Factor for temperature range 72/120°C: 0,83

**Table C90.2:** Characteristic resistance under shear load

Anchor rod	M6	M8	M6	M8	-	M8	M10	M8	M10	M10	M12	-	M12	M16	
Internal threaded anchor FIS E	-		-		M6	M8	-		-		-		M10	M12	-
					11x85								15x85		
Perforated sleeve FIS H K	12x50		12x85		16x85			16x130		18x130/200		20x85			

$V_{Rk} = V_{Rk,b} = V_{Rk,c}$  [kN] depending on the compressive strength  $f_b$  (temperature range 50/80°C and 72/120°C)

compressive strength $f_b$	use category		
	w/w	w/d	
2 N/mm <sup>2</sup>	w/w	w/d	0,9
	d/d		
4 N/mm <sup>2</sup>	w/w	w/d	1,5
	d/d		
6 N/mm <sup>2</sup>	w/w	w/d	2,5
	d/d		

Factor for job site tests and displacements see annex C110

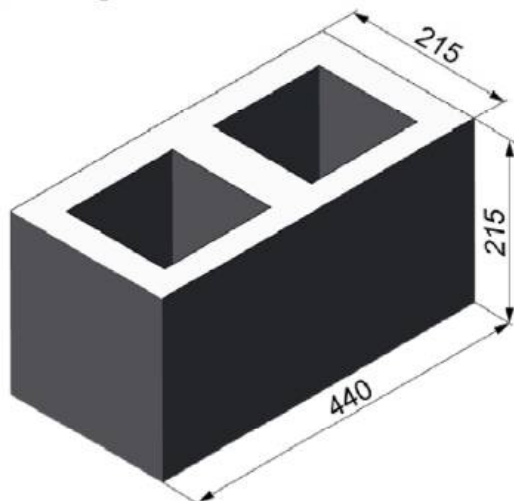
fischer injection system FIS V Plus for masonry

**Performance**

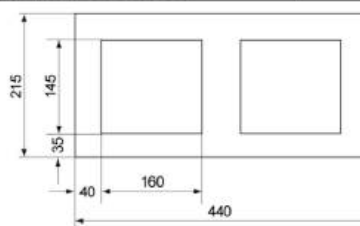
Light-weight concrete hollow block Hbl,  
Characteristic resistance under tension and shear load

**Annex C 90**

### Light-weight concrete hollow block Hbl, EN 771-3:2015



Light-weight concrete hollow block Hbl, EN 771-3:2015			
Producer	e.g. Roadstone wood		
Nominal dimensions [mm]	length L	width W	height H
	440	215	215
Density $\rho$ [kg/dm <sup>3</sup> ]	≥ 1,2		
Compressive strength $f_b$ [N/mm <sup>2</sup> ]	4 / 6 / 8 / 10		
Standard or annex	EN 771-3:2015		



Dimension see also Annex B 19

**Table C91.1:** Installation parameters  
(Pre-positioned anchorage with perforated sleeve FIS H K)

<b>Anchor rod</b>	M6	M8	M6	M8	-	M8	M10	M8	M10	-	M12	M16	M12	M16
<b>Internal threaded anchor FIS E</b>	-	-	M6	M8	M6	M8	-	-	M10	M12	-	-	-	-
			11x85						15x85					
<b>Perforated sleeve FIS H K</b>	12x50	12x85	16x85		16x130		20x85		20x130					

#### Anchor rod and internal threaded anchor FIS E with perforated sleeve FIS H K

Max. installation torque	$T_{inst}$ [Nm]	2												
<b>General installation parameters</b>														
Edge distance	$c_{min}$	110												
	$s_{min II}$	100												
	$s_{scr II}$ [mm]	440												
	$s_{min \perp}$	100												
	$s_{scr \perp}$	215												

#### Drilling method

Hammer drilling with hard metal hammer drill

**Table C91.2:** Group factors

<b>Anchor rod</b>	M6	M8	M6	M8	-	M8	M10	M8	M10	-	M12	M16	M12	M16
<b>Internal threaded anchor FIS E</b>	-	-	M6	M8	M6	M8	-	-	M10	M12	-	-	-	-
			11x85						15x85					
<b>Perforated sleeve FIS H K</b>	12x50	12x85	16x85		16x130		20x85		20x130					
Group factors	$\alpha_{g,N II}$	1,4												
	$\alpha_{g,v II}$	2,0												
	$\alpha_{g,N \perp}$	1,4												
	$\alpha_{g,v \perp}$	1,2												

fischer injection system FIS V Plus for masonry

**Performance**  
Light-weight concrete hollow block Hbl, dimensions, installation parameters

**Annex C 91**

### Light-weight concrete hollow block Hbl, EN 771-3:2015

**Table C92.1:** Installation parameters  
(Push through anchorage with perforated sleeve FIS H K)

Anchor rod		M10	M12	M16
Perforated sleeve FIS H K		18x130/200		22x130/200
Anchor rod with perforated sleeve FIS H K				
Max. installation torque	$T_{inst}$ [Nm]	2		
<b>General installation parameters</b>				
Edge distance	$c_{min}$	110		
Spacing	$s_{min \parallel}$	100		
	$s_{cr \parallel}$ [mm]	440		
	$s_{min \perp}$	100		
	$s_{cr \perp}$	215		
<b>Drilling method</b>				
Hammer drilling with hard metal hammer drill				

**Table C92.2:** Group factors

Anchor rod		M10	M12	M16
Perforated sleeve FIS H K		18x130/200		22x130/200
Group factors	$\alpha_{g,N \parallel}$	1,4		
	$\alpha_{g,V \parallel}$	2,0		
	$\alpha_{g,N \perp}$	1,4		
	$\alpha_{g,V \perp}$	1,2		

fischer injection system FIS V Plus for masonry

**Performance**  
Light-weight concrete hollow block Hbl, dimensions, installation parameters

**Annex C 92**



### Light-weight concrete hollow block Hbl, EN 771-3:2015

**Table C93.1:** Characteristic resistance under tension load (Pre-positioned anchorage)

Anchor rod	M6	M8	M6	M8	-	M8	M10	M8	M10	-	M12	M16	M12	M16
Internal threaded anchor FIS E	-	-	M6	M8	11x85	-	-	M10	M12	15x85	-	-	-	-
Perforated sleeve FIS H K	12x50	12x85	16x85			16x130			20x85			20x130		
<b><math>N_{Rk} = N_{Rk,p} = N_{Rk,b}</math> [kN] depending on the compressive strength <math>f_b</math> (temperature range 50/80°C)</b>														
compressive strength $f_b$	use category													
4 N/mm <sup>2</sup>	w/w	w/d	0,9			1,2			2,0					
	d/d		1,2			1,5			2,0					
6 N/mm <sup>2</sup>	w/w	w/d	1,5			2,0			3,0					
	d/d		1,5			2,0			3,0					
8 N/mm <sup>2</sup>	w/w	w/d	2,0			2,5			3,5					
	d/d		2,0			3,0			4,0					
10 N/mm <sup>2</sup>	w/w	w/d	2,5			3,0			4,5					
	d/d		3,0			3,5			5,0					

**Table C93.2:** Characteristic resistance under tension load (Push through anchorage)

Anchor rod	M10		M12		M16	
Perforated sleeve FIS H K	18x130/200				22x130/200	
<b><math>N_{Rk} = N_{Rk,p} = N_{Rk,b}</math> [kN] depending on the compressive strength <math>f_b</math> (temperature range 50/80°C)</b>						
compressive strength $f_b$	use category					
4 N/mm <sup>2</sup>	w/w	w/d	1,2		2,0	
	d/d		1,5		2,0	
6 N/mm <sup>2</sup>	w/w	w/d	2,0		3,0	
	d/d		2,0		3,0	
8 N/mm <sup>2</sup>	w/w	w/d	2,5		3,5	
	d/d		3,0		4,0	
10 N/mm <sup>2</sup>	w/w	w/d	3,0		4,5	
	d/d		3,5		5,0	

Factor for job site tests and displacements see annex C110

Factor for temperature range 72/120°C: 0,83

fischer injection system FIS V Plus for masonry

**Performance**  
Light-weight concrete hollow block Hbl, Characteristic resistance under tension load

**Annex C 93**

### Light-weight concrete hollow block Hbl, EN 771-3:2015

**Table C94.1:** Characteristic resistance under shear load (Pre-positioned anchorage)

Anchor rod		M6	M8	M6	M8	-	M8	M10	M8	M10	-	M12	M16	M12	M16	
Internal threaded anchor FIS E		-	-			M6	M8				M10	M12				
						11x85					15x85					
Perforated sleeve FIS H K		12x50		12x85		16x85			16x130		20x85			20x130		
<b><math>V_{Rk} = V_{Rk,b} = V_{Rk,c}</math> [kN] depending on the compressive strength <math>f_b</math> (temperature range 50/80°C and 72/120°C)</b>																
compressive strength $f_b$	use category															
4 N/mm <sup>2</sup>	w/w	0,75	1,2	0,75	1,2	0,75										1,2
	w/d															
6 N/mm <sup>2</sup>	w/w	1,2	2,0	1,2	2,0	1,2										2,0
	w/d															
8 N/mm <sup>2</sup>	w/w	1,5	2,5	1,5	2,5	1,5										2,5
	w/d															
10 N/mm <sup>2</sup>	w/w	2,0	3,0	2,0	3,0	2,0										3,0
	w/d															

**Table C94.2:** Characteristic resistance under shear load (Push through anchorage)

Anchor rod		M10		M12		M16		
Perforated sleeve FIS H K		18x130/200				22x130/200		
<b><math>V_{Rk} = V_{Rk,b} = V_{Rk,c}</math> [kN] depending on the compressive strength <math>f_b</math> (temperature range 50/80°C and 72/120°C)</b>								
compressive strength $f_b$	use category							
4 N/mm <sup>2</sup>	w/w							1,2
	w/d							
6 N/mm <sup>2</sup>	w/w							2,0
	w/d							
8 N/mm <sup>2</sup>	w/w							2,5
	w/d							
10 N/mm <sup>2</sup>	w/w							3,0
	w/d							

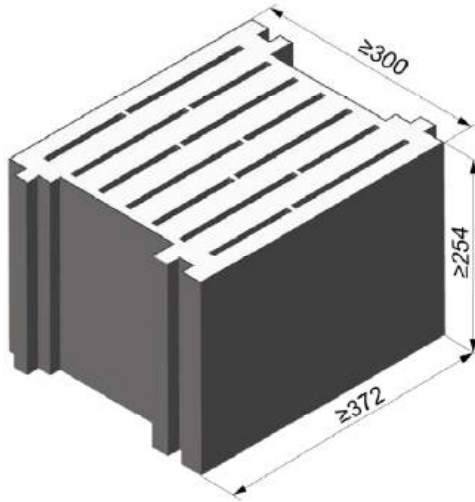
Factor for job site tests and displacements see annex C110

fischer injection system FIS V Plus for masonry

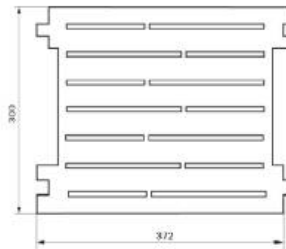
**Performance**  
Light-weight concrete hollow block Hbl, Characteristic resistance under shear load

**Annex C 94**

**Light-weight concrete solid block Vbl, EN 771-3:2015**



Light-weight concrete solid block Vbl, EN 771-3:2015			
Producer	e.g. Sepa		
Nominal dimensions [mm]	length L	width W	height H
	≥ 372	≥ 300	≥ 254
Density $\rho$ [kg/dm <sup>3</sup> ]	≥ 0,6		
Compressive strength $f_b$ [N/mm <sup>2</sup> ]	2		
Standard or annex	EN 771-3:2015		



**Table C95.1:** Installation parameters

Anchor rod	M8	M10	M10	M12	M12	M16	M16	M12	M16
Perforated sleeve FIS H K	16x130		18x130/200		20x130		22x130/200		20x200
Anchor rod with perforated sleeve FIS H K									
Max. installation torque $T_{inst}$ [Nm]	4								
General installation parameters									
Edge distance $c_{min}$	130								
Spacing $s_{min}$ [mm]	$s_{min} \parallel = s_{cr} \parallel$	370							
	$s_{min} \perp = s_{cr} \perp$	250							
Drilling method									
Hammer drilling with hard metal hammer drill									

**Table C95.2:** Group factors

Anchor rod	M8	M10	M10	M12	M12	M16	M16	M12	M16
Perforated sleeve FIS H K	16x130		18x130/200		20x130		22x130/200		20x200
Group factors	$\alpha_{g,N} \parallel$	[-]	2						
	$\alpha_{g,v} \parallel$								
	$\alpha_{g,N} \perp$								
	$\alpha_{g,v} \perp$								

fischer injection system FIS V Plus for masonry

**Performance**  
Light-weight concrete solid block Vbl, dimensions, installation parameters

**Annex C 95**

### Light-weight concrete solid block Vbl, EN 771-3:2015

**Table C96.1:** Characteristic resistance under tension load

Anchor rod	M8	M10	M10	M12	M12	M16	M16	M12	M16
Perforated sleeve FIS H K	16x130		18x130/200		20x130		22x130/200		20x200
<b><math>N_{Rk} = N_{Rk,p} = N_{Rk,b}</math> [kN] depending on the compressive strength <math>f_b</math> (temperature range 50/80°C)</b>									
compressive strength $f_b$	use category								
2 N/mm <sup>2</sup>	w/w	w/d	2,0			2,5			3,0
	d/d		2,0			3,0			4,0

Factor for temperature range 72/120°C: 0,83

**Table C96.2:** Characteristic resistance under shear load

Anchor rod	M8	M10	M10	M12	M12	M16	M16	M12	M16
Perforated sleeve FIS H K	16x130		18x130/200		20x130		22x130/200		20x200
<b><math>V_{Rk} = V_{Rk,b} = V_{Rk,c}</math> [kN] depending on the compressive strength <math>f_b</math> (temperature range 50/80°C and 72/120°C)</b>									
compressive strength $f_b$	use category								
2 N/mm <sup>2</sup>	w/w	w/d	4,5			6,5			
	d/d								

Factor for job site tests and displacements see annex C110

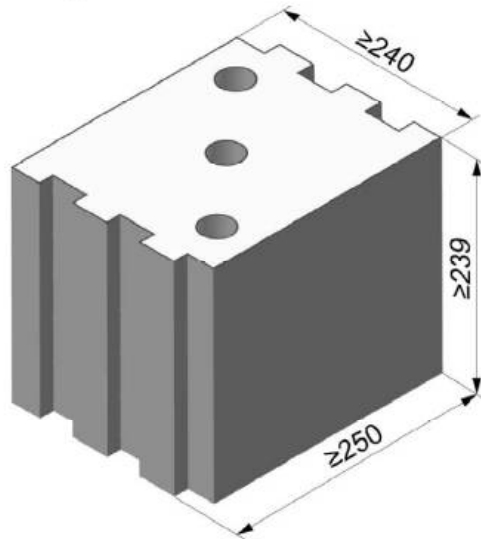
fischer injection system FIS V Plus for masonry

**Performance**

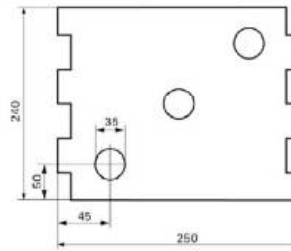
Light-weight concrete solid block Vbl,  
Characteristic resistance under tension and shear load

**Annex C 96**

**Light-weight concrete solid block Vbl, EN 771-3:2015**



Light-weight concrete solid block Vbl, EN 771-3:2015			
Producer	KLB		
Nominal dimensions [mm]	length L	width W	height H
	≥ 250	≥ 240	≥ 239
Density $\rho$ [kg/dm <sup>3</sup> ]	≥ 1,6		
Compressive strength $f_b$ [N/mm <sup>2</sup> ]	4 / 6 / 8		
Standard or annex	EN 771-3:2015		



Dimension see also Annex B 19

**Table C97.1:** Installation parameters  
(Pre-positioned anchorage with perforated sleeve FIS H K)

<b>Anchor rod</b>	M6	M8	M6	M8	-	M8	M10	M8	M10	-	M12	M16	M12	M16	M12	M16
<b>Internal threaded anchor FIS E</b>	-	-	-	-	M6	M8	-	-	-	M10	M12	-	-	-	-	-
					11x85					15x85						
<b>Perforated sleeve FIS H K</b>	12x50		12x85		16x85			16x130		20x85			20x130		20x200	
<b>Anchor rod and internal threaded anchor FIS E with perforated sleeve FIS H K</b>																
Max. installation torque	$T_{inst}$	[Nm]	4													
<b>General installation parameters</b>																
Edge distance	$C_{min}$	[mm]	130													
Spacing	$S_{min \parallel} = S_{cr \parallel}$	[mm]	250													
	$S_{min \perp} = S_{cr \perp}$	[mm]	250													
<b>Drilling method</b>																
Hammer drilling with hard metal hammer drill																

**Table C97.2:** Group factors

<b>Anchor rod</b>	M6	M8	M6	M8	-	M8	M10	M8	M10	-	M12	M16	M12	M16	M12	M16
<b>Internal threaded anchor FIS E</b>	-	-	-	-	M6	M8	-	-	-	M10	M12	-	-	-	-	-
					11x85					15x85						
<b>Perforated sleeve FIS H K</b>	12x50		12x85		16x85			16x130		20x85			20x130		20x200	
Group factors	$\alpha_{g,N \parallel}$	[-]	2,0													
	$\alpha_{g,v \parallel}$															
	$\alpha_{g,N \perp}$															
	$\alpha_{g,v \perp}$															

fischer injection system FIS V Plus for masonry

**Performance**  
Light-weight concrete solid block Vbl, dimensions, installation parameters

**Annex C 97**



**Light-weight concrete solid block Vbl, EN 771-3:2015**

**Table C98.1:** Installation parameters  
(Push through anchorage with perforated sleeve FIS H K)

Anchor rod	M10	M12	M16
Perforated sleeve FIS H K	18x130/200		22x130/200
<b>Anchor rod with perforated sleeve FIS H K</b>			
Max. installation torque	$T_{inst}$ [Nm]	2	
<b>General installation parameters</b>			
Edge distance	$c_{min}$	130	
Spacing	$s_{min \parallel} = s_{cr \parallel}$ [mm]	250	
	$s_{min \perp} = s_{cr \perp}$	250	
<b>Drilling method</b>			
Hammer drilling with hard metal hammer drill			

**Table C98.2:** Group factors

Anchor rod	M10	M12	M16
Perforated sleeve FIS H K	18x130/200		22x130/200
Group factors	$\alpha_{g,N \parallel}$	2,0	[-]
	$\alpha_{g,V \parallel}$		
	$\alpha_{g,N \perp}$		
	$\alpha_{g,V \perp}$		

fischer injection system FIS V Plus for masonry

**Performance**  
Light-weight concrete solid block Vbl, dimensions, installation parameters

**Annex C 98**

### Light-weight concrete solid block Vbl, EN 771-3:2015

**Table C99.1:** Characteristic resistance under tension load (Pre-positioned anchorage)

Anchor rod	M6	M8	M6	M8	-	M8	M10	M8	M10	-	M12	M16	M12	M16	M12	M16
Internal threaded anchor FIS E	-	-			M6	M8				M10	M12					
					11x85					15x85						
Perforated sleeve FIS H K	12x50		12x85		16x85			16x130			20x85		20x130		20x200	
<b><math>N_{Rk} = N_{Rk,p} = N_{Rk,b}</math> [kN] depending on the compressive strength <math>f_b</math> (temperature range 50/80°C)</b>																
compressive strength $f_b$	use category															
4 N/mm <sup>2</sup>	w/w	w/d	1,2	2,0	2,5			3,0								
	d/d		2,0	3,5	4,0			5,0								
6 N/mm <sup>2</sup>	w/w	w/d	1,5	3,0	4,0			5,0								
	d/d		3,0	5,0	6,5			7,5								
8 N/mm <sup>2</sup>	w/w	w/d	2,0	4,0	5,0			6,5								
	d/d		4,0	7,0	8,5			9,0								

**Table C99.2:** Characteristic resistance under tension load (Push through anchorage)

Anchor rod	M10		M12		M16	
Perforated sleeve FIS H K	18x130/200				22x130/200	
<b><math>N_{Rk} = N_{Rk,p} = N_{Rk,b}</math> [kN] depending on the compressive strength <math>f_b</math> (temperature range 50/80°C)</b>						
compressive strength $f_b$	use category					
4 N/mm <sup>2</sup>	w/w	w/d	2,5		3,0	
	d/d		4,0		5,0	
6 N/mm <sup>2</sup>	w/w	w/d	4,0		5,0	
	d/d		6,5		7,5	
8 N/mm <sup>2</sup>	w/w	w/d	5,0		6,5	
	d/d		8,5		9,0	

Factor for job site tests and displacements see annex C110

Factor for temperature range 72/120°C: 0,83

fischer injection system FIS V Plus for masonry

**Performance**

Light-weight concrete solid block Vbl, Characteristic resistance under tension load

**Annex C 99**

### Light-weight concrete solid block Vbl, EN 771-3:2015

**Table C100.1:** Characteristic resistance under shear load (Pre-positioned anchorage)

Anchor rod	M6	M8	M6	M8	-	M8	M10	M8	M10	-	M12	M16	M12	M16	M12	M16
Internal threaded anchor FIS E	-	-	-	-	M6	M8	-	-	M10	M12	-	-	-	-	-	-
					11x85				15x85							
Perforated sleeve FIS H K	12x50		12x85		16x85			16x130		20x85			20x130		20x200	

$V_{Rk} = V_{Rk,b} = V_{Rk,c}$  [kN] depending on the compressive strength  $f_b$  (temperature range 50/80°C and 72/120°C)

compressive strength $f_b$	use category													
	w/w	w/d												
4 N/mm <sup>2</sup>	w/w	w/d	2,0	3,0	2,0	3,0	2,0	3,5					4,5	
	d/d													
6 N/mm <sup>2</sup>	w/w	w/d	3,0	4,5	3,0	4,5	3,0	5,5					6,5	
	d/d													
8 N/mm <sup>2</sup>	w/w	w/d	4,0	6,0	4,0	6,0	4,0	7,0					8,5	
	d/d													

**Table C100.2:** Characteristic resistance under shear load (Push through anchorage)

Anchor rod	M10	M12	M16
Perforated sleeve FIS H K	18x130/200		22x130/200

$V_{Rk} = V_{Rk,b} = V_{Rk,c}$  [kN] depending on the compressive strength  $f_b$  (temperature range 50/80°C and 72/120°C)

compressive strength $f_b$	use category							
	w/w	w/d						
4 N/mm <sup>2</sup>	w/w	w/d	3,5			4,5		
	d/d							
6 N/mm <sup>2</sup>	w/w	w/d	5,5			6,5		
	d/d							
8 N/mm <sup>2</sup>	w/w	w/d	7,0			8,5		
	d/d							

Factor for job site tests and displacements see annex C110

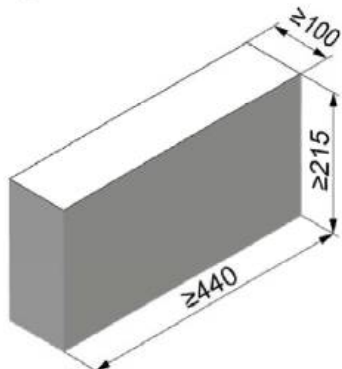
fischer injection system FIS V Plus for masonry

**Performance**

Light-weight concrete solid block Vbl, Characteristic resistance under shear load

**Annex C 100**

### Light-weight concrete solid block Vbl, EN 771-3:2015



Light-weight concrete solid block Vbl, EN 771-3:2015			
Producer	Roadstone wood		
Nominal dimensions [mm]	length L	width W	height H
	≥ 440	≥ 100	≥ 215
Density $\rho$ [kg/dm <sup>3</sup> ]	≥ 2,0		
Compressive strength $f_b$ [N/mm <sup>2</sup> ]	4 / 6 / 8 / 10		
Standard or annex	EN 771-3:2015		

**Table C101.1:** Installation parameters

Anchor rod	M6	M8	M10	M12	M16	
<b>Anchor rod without perforated sleeve</b>						
Effective anchorage depth $h_{ef}$ [mm]	50	70	50	70	50	70
Max. installation torque $T_{inst}$ [Nm]	4		10			
<b>General installation parameters</b>						
Edge distance $c_{min}$	100					
$s_{min \parallel}$	75					
Spacing	$s_{cr \parallel}$ [mm]	3x $h_{ef}$				
	$s_{min \perp}$	75				
	$s_{cr \perp}$	3x $h_{ef}$				
<b>Drilling method</b>						
Hammer drilling with hard metal hammer drill						

**Table C101.2:** Group factors

Anchor rod	M6	M8	M10	M12	M16
Group factors	$\alpha_{g,N \parallel}$	1,6			
	$\alpha_{g,V \parallel}$	1,3			
	$\alpha_{g,N \perp}$	1,4			
	$\alpha_{g,V \perp}$	1,3			

fischer injection system FIS V Plus for masonry

**Performance**

Light-weight concrete solid block Vbl, dimensions, installation parameters

**Annex C 101**

### Light-weight concrete solid block Vbl, EN 771-3:2015

**Table C102.1:** Characteristic resistance under tension load

Anchor rod		M6	M8	M10	M12	M16
<b><math>N_{Rk} = N_{Rk,p} = N_{Rk,b}</math> [kN] depending on the compressive strength <math>f_b</math> (temperature range 50/80°C)</b>						
compressive strength $f_b$	use category		Effective anchorage depth $h_{ef}$ [mm]			
			≥ 50			
4 N/mm <sup>2</sup>	w/w	w/d	1,2		1,2	
	d/d		2,0		2,0	
6 N/mm <sup>2</sup>	w/w	w/d	1,5		2,0	
	d/d		3,0		3,5	
8 N/mm <sup>2</sup>	w/w	w/d	2,0		2,5	
	d/d		4,0		4,5	
10N/mm <sup>2</sup>	w/w	w/d	3,0		3,5	
	d/d		5,0		5,5	

Factor for temperature range 72/120°C: 0,83

**Table C102.2:** Characteristic resistance under shear load

Anchor rod		M6	M8	M10	M12	M16
<b><math>V_{Rk} = V_{Rk,b} = V_{Rk,c}</math> [kN] depending on the compressive strength <math>f_b</math> (temperature range 50/80°C and 72/120°C)</b>						
compressive strength $f_b$	use category		Effective anchorage depth $h_{ef}$ [mm]			
			≥ 50			
4 N/mm <sup>2</sup>	w/w	w/d	1,2	1,5	1,5	1,5
	d/d					
6 N/mm <sup>2</sup>	w/w	w/d	2,0	2,0	2,5	2,5
	d/d					
8 N/mm <sup>2</sup>	w/w	w/d	2,5	2,5	3,0	3,0
	d/d					
10N/mm <sup>2</sup>	w/w	w/d	3,0	3,5	4,0	4,0
	d/d					

Factor for job site tests and displacements see annex C110

fischer injection system FIS V Plus for masonry

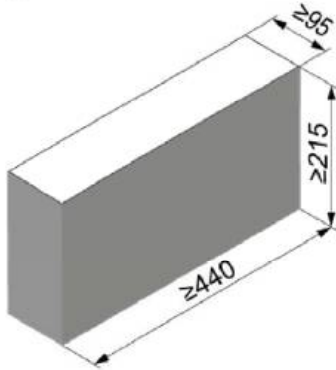
**Performance**

Light-weight concrete solid block Vbl,  
Characteristic resistance under tension and shear load

**Annex C 102**



### Light-weight concrete solid block Vbl, EN 771-3:2015



Light-weight concrete solid block Vbl, EN 771-3:2015			
Producer	Tramac		
Nominal dimensions [mm]	length L	width W	height H
	≥ 440	≥ 95	≥ 215
Density $\rho$ [kg/dm <sup>3</sup> ]	≥ 2,0		
Compressive strength $f_b$ [N/mm <sup>2</sup> ]	6 / 8 / 10 / 12		
Standard or annex	EN 771-3:2015		

**Table C103.1:** Installation parameters

Anchor rod	M6		M8		M10		M12		M16	
Anchor rod without perforated sleeve										
Effective anchorage depth $h_{ef}$ [mm]	50	70	50	70	50	70	50	70	50	70
Max. installation torque $T_{inst}$ [Nm]	4				10					
General installation parameters										
Edge distance $c_{min}$	60									
Spacing	$s_{min \parallel}$	75								
	$s_{scr \parallel}$	3x $h_{ef}$								
	$s_{min \perp}$	75								
	$s_{scr \perp}$	3x $h_{ef}$								
Drilling method										
Hammer drilling with hard metal hammer drill										

**Table C103.2:** Group factors

Anchor rod	M6		M8		M10		M12		M16	
Group factors	$\alpha_{g,N \parallel}$	1,9								
	$\alpha_{g,V \parallel}$	1,4								
	$\alpha_{g,N \perp}$	1,9								
	$\alpha_{g,V \perp}$	1,4								

fischer injection system FIS V Plus for masonry

**Performance**  
Light-weight concrete solid block Vbl, dimensions, installation parameters

**Annex C 103**

### Light-weight concrete solid block Vbl, EN 771-3:2015

**Table C104.1:** Characteristic resistance under tension load

Anchor rod		M6	M8	M10	M12	M16					
<b><math>N_{Rk} = N_{Rk,p} = N_{Rk,b}</math> [kN] depending on the compressive strength <math>f_b</math> (temperature range 50/80°C)</b>											
compressive strength $f_b$	use category	Effective anchorage depth $h_{ef}$ [mm]									
		50	70	50	70	50	70	50	70	50	70
6 N/mm <sup>2</sup>	w/w   w/d	1,5	2,0	1,5	2,0	1,5	2,0	1,5	2,0	1,5	2,0
	d/d	2,5	3,5	2,5	3,5	2,5	3,5	2,5	3,5	2,5	3,5
8 N/mm <sup>2</sup>	w/w   w/d	2,0	2,5	2,0	2,5	2,0	3,0	2,0	3,0	2,0	3,0
	d/d	3,5	4,5	3,5	4,5	3,5	5,0	3,5	5,0	3,5	5,0
10N/mm <sup>2</sup>	w/w   w/d	2,5	3,5	2,5	3,5	2,5	3,5	2,5	3,5	2,5	3,5
	d/d	4,5	6,0	4,5	6,0	4,5	6,0	4,5	6,0	4,5	6,0
12N/mm <sup>2</sup>	w/w   w/d	3,0	4,0	3,0	4,0	3,0	4,5	3,0	4,5	3,0	4,5
	d/d	5,0	7,0	5,0	7,0	5,0	7,5	5,0	7,5	5,0	7,5

Factor for temperature range 72/120°C: 0,83

**Table C104.2:** Characteristic resistance under shear load

Anchor rod		M6	M8	M10	M12	M16
<b><math>V_{Rk} = V_{Rk,b} = V_{Rk,c}</math> [kN] depending on the compressive strength <math>f_b</math> (temperature range 50/80°C and 72/120°C)</b>						
compressive strength $f_b$	use category	Effective anchorage depth $h_{ef}$ [mm]				
		≥ 50				
6 N/mm <sup>2</sup>	w/w   w/d	2,0	2,0	2,0	1,5	1,5
	d/d					
8 N/mm <sup>2</sup>	w/w   w/d	2,5	2,5	3,0	2,5	2,5
	d/d					
10N/mm <sup>2</sup>	w/w   w/d	3,5	3,5	4,0	3,0	3,0
	d/d					
12N/mm <sup>2</sup>	w/w   w/d	4,0	4,0	4,5	3,5	3,5
	d/d					

Factor for job site tests and displacements see annex C110

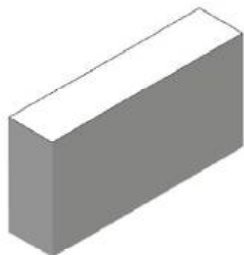
fischer injection system FIS V Plus for masonry

**Performance**

Light-weight concrete solid block Vbl,  
Characteristic resistance under tension and shear load

**Annex C 104**

### Autoclaved aerated concrete (cylindrical drill hole), EN 771-4:2015



Autoclaved aerated concrete, EN 771-4:2015			
Producer	e.g. Ytong		
Density $\rho$ [kg/dm <sup>3</sup> ]	0,35	0,5	0,65
Compressive strength $f_b$ [N/mm <sup>2</sup> ]	2	4	6
Standard or annex	EN 771-4:2015		

**Table C105.1:** Installation parameters

Anchor rod	M6	M8	M10	M12	M16	-	-
Internal threaded anchor FIS E	-	-	-	-	-	M6	M8
	11x85		15x85				
<b>Anchor rod and internal threaded anchor FIS E without perforated sleeve</b>							
Effective anchorage depth $h_{ef}$ [mm]	100	200	100	200	100	200	85
Max. installation torque $T_{inst}$ [Nm]	1	4	1	8	2	12	2
<b>General installation parameters</b>							
Edge distance $c_{min}$	100						
Spacing	$s_{cr \parallel} = s_{min \parallel}$	250					
	$h_{ef}=200mm$ $s_{min \parallel}$ [mm]	80					
	$h_{ef}=200mm$ $s_{cr \parallel}$	3x $h_{ef}$					
	$s_{cr \perp} = s_{min \perp}$	250					
	$h_{ef}=200mm$ $s_{min \perp}$	80					
	$h_{ef}=200mm$ $s_{cr \perp}$	3x $h_{ef}$					
<b>Drilling method</b>							
Hammer drilling with hard metal hammer drill							
fischer injection system FIS V Plus for masonry						<b>Annex C 105</b>	
<b>Performance</b> Autoclaved aerated concrete (cylindrical drill hole), dimensions, installation parameters							

**Table C106.1:** Group factors for autoclaved aerated concrete  
(Compressive strength  $f_b = 2 \text{ N/mm}^2$ )

Anchor rod	M6	M8	M10	M12	M16	-		-	
Internal threaded anchor FIS E	-	-	-	-	-	M6	M8	M10	M12
						11x85		15x85	
Group factors	$h_{ef}=200 \alpha_{g,N} \parallel$	[-]	1,6			- <sup>1)</sup>		- <sup>1)</sup>	
	$h_{ef}=200 \alpha_{g,V} \parallel$		1,1			- <sup>1)</sup>		- <sup>1)</sup>	
	$\alpha_{g,N} \parallel, \alpha_{g,V} \parallel$		2						
	$h_{ef}=200 \alpha_{g,N} \perp$		1,6			- <sup>1)</sup>		- <sup>1)</sup>	
	$h_{ef}=200 \alpha_{g,V} \perp$		0,8			- <sup>1)</sup>		- <sup>1)</sup>	
	$\alpha_{g,N} \perp, \alpha_{g,V} \perp$		2						

<sup>1)</sup> No performance assessed

**Table C106.2:** Group factors for autoclaved aerated concrete  
(Compressive strength  $f_b = 4 \text{ N/mm}^2$ )

Anchor rod	M6	M8	M10	M12	M16	-		-	
Internal threaded anchor FIS E	-	-	-	-	-	M6	M8	M10	M12
						11x85		15x85	
Group factors	$h_{ef}=200 \alpha_{g,N} \parallel$	[-]	0,7			- <sup>1)</sup>		- <sup>1)</sup>	
	$h_{ef}=200 \alpha_{g,V} \parallel$		2,0			- <sup>1)</sup>		- <sup>1)</sup>	
	$\alpha_{g,N} \parallel, \alpha_{g,V} \parallel$		2						
	$h_{ef}=200 \alpha_{g,N} \perp$		0,7			- <sup>1)</sup>		- <sup>1)</sup>	
	$h_{ef}=200 \alpha_{g,V} \perp$		1,2			- <sup>1)</sup>		- <sup>1)</sup>	
	$\alpha_{g,N} \perp, \alpha_{g,V} \perp$		2						

<sup>1)</sup> No performance assessed

**Table C106.3:** Group factors for autoclaved aerated concrete  
(Compressive strength  $f_b = 6 \text{ N/mm}^2$ )

Anchor rod	M6	M8	M10	M12	M16	-		-	
Internal threaded anchor FIS E	-	-	-	-	-	M6	M8	M10	M12
						11x85		15x85	
Group factors	$h_{ef}=200 \alpha_{g,N} \parallel$	[-]	0,7			- <sup>1)</sup>		- <sup>1)</sup>	
	$h_{ef}=200 \alpha_{g,V} \parallel$		2,0			- <sup>1)</sup>		- <sup>1)</sup>	
	$\alpha_{g,N} \parallel, \alpha_{g,V} \parallel$		2						
	$h_{ef}=200 \alpha_{g,N} \perp$		0,7			- <sup>1)</sup>		- <sup>1)</sup>	
	$h_{ef}=200 \alpha_{g,V} \perp$		1,2			- <sup>1)</sup>		- <sup>1)</sup>	
	$\alpha_{g,N} \perp, \alpha_{g,V} \perp$		2						

<sup>1)</sup> No performance assessed

fischer injection system FIS V Plus for masonry

**Performance**  
Autoclaved aerated concrete (cylindrical drill hole), Group factors

**Annex C 106**

**Autoclaved aerated concrete (cylindrical drill hole), EN 771-4:2015**

**Table C107.1: Characteristic resistance under tension load**

Anchor rod		M6		M8		M10		M12		M16		-		-	
Internal threaded anchor FIS E		-		-		-		-		-		M6	M8	M10	M12
												11x85		15x85	
<b><math>N_{Rk} = N_{Rk,p} = N_{Rk,b}</math> [kN] depending on the compressive strength <math>f_b</math> (temperature range 50/80°C)</b>															
compressive strength $f_b$	use category		Effective anchorage depth $h_{ef}$ [mm]										85		
	100	200	100	200	100	200	100	200	100	200	100	200			
2 N/mm <sup>2</sup>	w/w	w/d	1,2	1,2	1,5	2,0	1,5	3,0	1,5	3,0	2,0	3,0	1,5	1,5	
	d/d		1,5	3,0	1,5	3,0	1,5	3,5	2,0	4,0	2,0	4,0	1,5	1,5	
4 N/mm <sup>2</sup>	w/w	w/d	1,2	- <sup>1)</sup>	2,0	1,5	2,5	3,5	2,5	3,5	2,0	3,5	2,0	1,5	
	d/d		1,5	- <sup>1)</sup>	2,0	3,0	3,0	5,0	2,5	5,0	2,0	5,0	2,0	1,5	
6 N/mm <sup>2</sup>	w/w	w/d	1,5	- <sup>1)</sup>	3,0	2,5	4,5	5,0	4,5	7,0	3,0	8,5	3,5	2,5	
	d/d		1,5	- <sup>1)</sup>	3,5	4,0	5,0	7,0	5,0	9,0	3,0	11,5	3,5	2,5	

<sup>1)</sup> No performance assessed

Factor for temperature range 72/120°C: 0,83

**Table C107.2: Characteristic resistance under shear load**

Anchor rod		M6		M8		M10		M12		M16		-		-	
Internal threaded anchor FIS E		-		-		-		-		-		M6	M8	M10	M12
												11x85		15x85	
<b><math>V_{Rk} = V_{Rk,b} = V_{Rk,c}</math> [kN] depending on the compressive strength <math>f_b</math> (temperature range 50/80°C and 72/120°C)</b>															
compressive strength $f_b$	use category		Effective anchorage depth $h_{ef}$ [mm]										85		
	100	200	100	200	100	200	100	200	100	200	100	200			
2 N/mm <sup>2</sup>	w/w	w/d	1,2	1,2	1,2	1,2	1,2	1,2	1,5	1,2	1,2	1,2	1,2	1,5	
	d/d														
4 N/mm <sup>2</sup>	w/w	w/d	2,0	- <sup>1)</sup>	2,5	2,0	2,0	2,0	2,5	2,0	2,0	2,0	2,0	2,5	
	d/d														
6 N/mm <sup>2</sup>	w/w	w/d	2,5	- <sup>1)</sup>	3,0	2,5	3,0	3,0	3,5	4,0	4,5	4,5	2,5	3,5	
	d/d														

<sup>1)</sup> No performance assessed

Factor for job site tests and displacements see annex C110

fischer injection system FIS V Plus for masonry

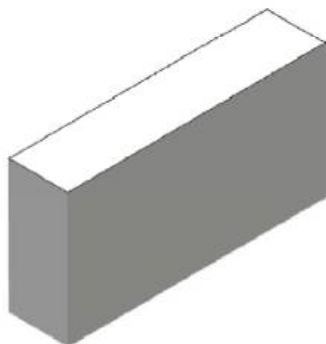
**Performance**  
Autoclaved aerated concrete (cylindrical drill hole),  
Characteristic resistance under tension and shear load

**Annex C 107**



**Autoclaved aerated concrete (conical drill hole with special drill bit PBB),**

**EN 771-4:2015**



Autoclaved aerated concrete, EN 771-4:2015				
Producer	e.g. Ytong			
Density $\rho$	[kg/dm <sup>3</sup> ]	0,35	0,5	0,65
Compressive strength $f_b$	[N/mm <sup>2</sup> ]	2	4	6
Standard or annex	EN 771-4:2015			

**Table C108.1: Installation parameters**

Anchor rod	M8		M10		M12		-			
Internal threaded anchor FIS E	-	-	-	-	-	-	M6	M8		
								11x85		
Anchor rod and internal threaded anchor FIS E without perforated sleeve										
Effective anchorage depth	$h_{ef}$	[mm]	75	95	75	95	75	95	85	
Max. installation torque	$T_{inst}$	[Nm]	2							
General installation parameters										
Edge distance	$c_{min}$		120	150	120	150	120	150	150	
Spacing	$s_{cr \parallel} = s_{min \parallel}$	[mm]	240	300	240	300	240	300	300	
	$s_{cr \perp} = s_{min \perp}$		240	250	240	250	240	250	250	
Drilling method										
Hammer drilling with hard metal hammer drill										

**Table C108.2: Group factors**

Anchor rod	M8		M10		M12		-			
Internal threaded anchor FIS E	-	-	-	-	-	-	M6	M8		
								11x85		
Group factors	$\alpha_{g,N \parallel}$	[-]	2							
	$\alpha_{g,V \parallel}$									
	$\alpha_{g,N \perp}$									
	$\alpha_{g,V \perp}$									

fischer injection system FIS V Plus for masonry

**Performance**

Autoclaved aerated concrete (conical drill hole with special drill bit PBB),  
dimensions, installation parameters

**Annex C 108**

**Autoclaved aerated concrete (conical drill hole with special drill bit PBB),  
EN 771-4:2015**

**Table C109.1:** Characteristic resistance under tension load

Anchor rod		M8		M10		M12		-	
Internal threaded anchor FIS E		-	-	-	-	-	-	M6	M8
11x85									
<b><math>N_{Rk} = N_{Rk,p} = N_{Rk,b}</math> [kN] depending on the compressive strength <math>f_b</math> (temperature range 50/80°C)</b>									
compressive strength $f_b$	use category	Effective anchorage depth $h_{ef}$ [mm]							
		75	95	75	95	75	95	85	
2 N/mm <sup>2</sup>	w/w   w/d	2,0	2,5	2,0	2,5	2,0	2,5	2,0	2,0
	d/d	2,0	2,5	2,0	2,5	2,0	2,5	2,0	2,0
4 N/mm <sup>2</sup>	w/w   w/d	3,0	3,5	3,0	3,5	3,0	3,5	3,0	3,0
	d/d	3,0	3,5	3,0	3,5	3,0	3,5	3,0	3,0
6 N/mm <sup>2</sup>	w/w   w/d	3,5	4,0	3,5	4,0	3,5	4,0	3,5	3,5
	d/d	4,0	4,5	4,0	4,5	4,0	4,5	4,0	4,0

Factor for temperature range 72/120°C: 0,83

**Table C109.2:** Characteristic resistance under shear load

Anchor rod		M8		M10		M12		-	
Internal threaded anchor FIS E		-	-	-	-	-	-	M6	M8
11x85									
<b><math>V_{Rk} = V_{Rk,b} = V_{Rk,c}</math> [kN] depending on the compressive strength <math>f_b</math> (temperature range 50/80°C and 72/120°C)</b>									
compressive strength $f_b$	use category	Effective anchorage depth $h_{ef}$ [mm]							
		75	95	75	95	75	95	85	
2 N/mm <sup>2</sup>	w/w   w/d	2,5							
	d/d								
4 N/mm <sup>2</sup>	w/w   w/d	4,5							
	d/d								
6 N/mm <sup>2</sup>	w/w   w/d	6,0							
	d/d								

Factor for job site tests and displacements see annex C110

fischer injection system FIS V Plus for masonry

**Performance**

Autoclaved aerated concrete (conical drill hole with special drill bit PBB),  
Characteristic resistance under tension and shear load

**Annex C 109**

### β-factors for job site tests; displacements

**Table C110.1:** β-factors for job site tests

use category		w/w and w/d		d/d	
temperature range		50/80	72/120	50/80	72/120
Material	Size				
solid units	M6	0,55	0,46	0,96	0,80
	M8	0,57	0,51		
	M10	0,59	0,52		
	M12 FIS E 11x85	0,6	0,54		
	M16 FIS E 15x85	0,62	0,52		
	FIS H 16x85 K	0,55	0,46		
hollow units	all sizes	0,86	0,72	0,96	0,8
Autoclaved aerated concrete cylindrical drill hole	all sizes	0,73	0,73	0,81	0,81
Autoclaved aerated concrete conical drill hole	all sizes	0,66	0,59	0,73	0,66

**Table C110.2:** Displacements

Material	N [kN]	δN <sub>0</sub> [mm]	δN <sub>∞</sub> [mm]	V [kN]	δV <sub>0</sub> [mm]	δV <sub>∞</sub> [mm]
solid units and autoclaved aerated concrete h <sub>ef</sub> =100mm	$\frac{N_{Rk}}{1,4 * \gamma_{Mm}}$	0,03	0,06	$\frac{V_{Rk}}{1,4 * \gamma_{Mm}}$	0,82	0,88
hollow units	$\frac{N_{Rk}}{1,4 * \gamma_{Mm}}$	0,48	0,06	$\frac{V_{Rk}}{1,4 * \gamma_{Mm}}$	1,71	2,56
solid brick Mz NF annex C 4 - C 7	$\frac{N_{Rk}}{1,4 * \gamma_{Mm}}$	0,74	1,48	$\frac{V_{Rk}}{1,4 * \gamma_{Mm}}$	1,23	1,85
solid brick KS NF annex C 14 / C 15	$\frac{N_{Rk}}{1,4 * \gamma_{Mm}}$	0,2	0,4	$\frac{V_{Rk}}{1,4 * \gamma_{Mm}}$	0,91	1,37
AAC h <sub>ef</sub> =200 mm annex C 105 - C 107	$\frac{N_{Rk}}{1,4 * \gamma_{Mm}}$	1,03	2,06	$\frac{V_{Rk}}{1,4 * \gamma_{Mm}}$	1,25	1,88
brick Annex C 89 / C 90	$\frac{N_{Rk}}{1,4 * \gamma_{Mm}}$	0,03	0,06	$\frac{V_{Rk}}{1,4 * \gamma_{Mm}}$	6,44	9,66

For anchorage in autoclaved aerated concrete, the partial factor  $\gamma_{MAAC}$  shall be used instead of  $\gamma_{Mm}$ .

fischer injection system FIS V Plus for masonry

**Performance**  
β-factors for job site tests; displacements

**Annex C 110**